

CLAY ALLISON, SHERIFF KILLER

DOUBLE ACTION

WESTERN

AUG. 1959

35¢

PDC

**OUTLAWS OF
DUST CANYON**
by Saul Anthony

**IMPOSSIBLE
ESCAPE**
by Richard H.
Burgess

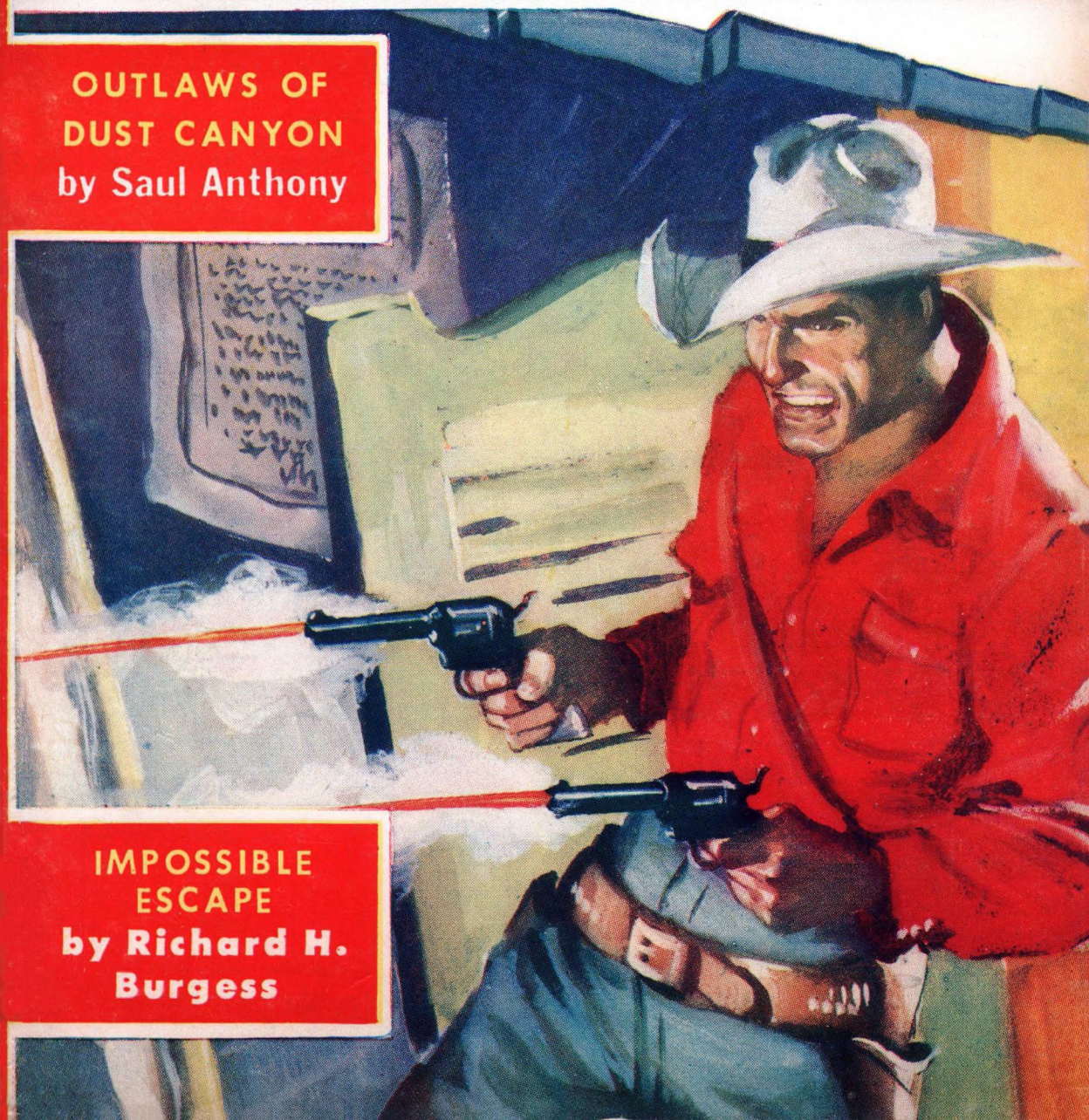



SKINNY

MEN ARE OFTEN ASHAMED TO STRIP FOR SPORTS OR FOR A SWIM AND GIRLS ARE NOT ALLURING AND DON'T HAVE EYE-CATCHING CURVES! CHILDREN WHO WON'T EAT AND ARE UNDERWEIGHT, OFTEN CALLED SKINNY!

Now at last More-Wate plan that puts firm, attractive pounds and inches on your body, chest, arms and legs.

GAIN MORE WEIGHT START GAINING WEIGHT IN 24 HOURS!

Amazing New Way developed by modern medical science to put on weight on lean bodies. Guaranteed to give you up to an extra pound a day! Or your money back! Why should you dress going to parties and socials, simply because you look scrawny and spindly? Why ever feel self-conscious about your body again? If you're underweights . . . or just a little on the thin side, due to faulty appetite, or bad dietary habits, you can put on up to a pound a day of attractive weight without exercise . . . dangerous drugs . . . or special diet . . . and more quickly, more easily than you ever dreamed possible with MORE-WATE. MORE-WATE contains no dangerous drugs . . . you eat it like candy! Yet . . . if you were to have this same prescription compounded to your order, it would cost you many times more. However, through this introductory offer, you can obtain 4-way MORE-WATE tablets . . . a full 30-day supply for only \$2.98 with an absolute money-back guarantee! Yes, try MORE-WATE for TEN DAYS . . . and if not entirely delighted with weight gained, return the unused supply for full refund! You've nothing to lose . . . and weight to gain! Act now! Stop being the guy or the gal that everyone calls "skinny." Stop being the guy or the gal who dreads summer and going to parties and socials because it means everyone will enjoy themselves and you won't. Don't be a wallflower, because you have a figure like a



broomstick! Gain more weight!

30-DAY SUPPLY ONLY \$2.98



The 4-way MORE-WATE tablets are unconditionally guaranteed to put on weight or it doesn't cost you a penny! MORE-WATE is a delicious, full strength, 4-way tablet . . . that combines not just one . . . or two . . . but 4 of the most amazing aids for gaining weight known to medical science. MORE-WATE is not a liquid . . . not a powder. It's a delicious, pleasant-tasting tablet! It contains vitamin B-12 . . . the amazing red vitamin doctors give many underweight patients in hospitals . . . It contains Iron that helps correct iron deficiency, anemia and builds rich red blood. It contains appetite-building vitamin B-1 . . . and it contains nutritious easily assimilated malt, the amazing ingredient that helps your body turn much of the food you eat into well rounded flesh instead of being wasted. That's the secret of putting on weight. Now you can help your food to add new pounds to your arms, chest, hips, thighs, and legs. Now you don't have to be skinny . . . or afraid to be seen socially and be ashamed of your figure! You must achieve the figure you want . . . or don't pay anything. Act now!

SENSATIONAL 10-DAY TEST!

Mail the coupon now! Test the amazing MORE-WATE tablet plan for 10 days at our expense. If after 10 days your friends, your mirror and you scale do not tell you that you have gained weight and look better, you pay nothing!

Not one child yet has failed to go for and ask for more MORE-WATE tablets! Stop worrying about children not eating enough, give them MORE-WATE tablets—it stimulates their appetite . . . they eat it like candy!

MAIL THIS NO RISK TRIAL COUPON NOW!

More-Wate Company, Dept. M366
403 Market Street, Newark, N. J.

Just mail your name and address and \$2.98 cash, check or money order. You will receive a 30-day supply of MORE-WATE TAB-

LETS (Improved formula) and MORE-WATE PLAN postage prepaid.

Send me Special 30-day supply package for \$2.98. I understand that if I am not delighted with MORE-WATE and MORE-WATE PLAN I can return in 10 days for full purchase price refund.

NAME ADDRESS

City STATE

SENT ON APPROVAL—MAKE AMAZING 10-DAY TEST

Cast your ballot for a successful future!

256 I.C.S. COURSES



Whether you stand at a machine or sit at a desk . . . whether you're making \$75 a week or \$75 hundred a year . . . whether your interest is Power Plants or Paper Pulp, Advertising or Electronics . . . chances are I.C.S. has exactly the course you need to get ahead.

I.C.S. is not only the oldest and largest correspondence school. It also offers the most courses, 256 in all. Each one success-proved by graduates who rose to top technical and administrative positions. Chief engineers, Superintendents, Foremen, Managers, Executive assistants.

I.C.S. Courses cover both book facts and theory plus practical, on-the-job applications. No skipping. Tests

are prepared by leading business and industrial authorities working with I.C.S. editors and educators. They are constantly being reviewed and revised in line with current developments.

As an I.C.S. student, you study in your spare time, set your own pace. No time lost getting to class or waiting for slower students to catch up. If you wish, I.C.S. will make progress reports to your employer. You win recognition as a "comer," one who is ready to move ahead. Thousands of students report pay increases and promotions within a few months of enrollment. All graduates win the coveted, approved I.C.S. diploma.

3 FREE BOOKS! Check the subject that interests you in the coupon below. I.C.S. will rush you (1) a special book outlining your opportunities in this field, (2) the 32-page gold mine of career tips, "How to Succeed," (3) a sample I.C.S. lesson (Math.) demonstrating the famous "I.C.S. Method." "X" MARKS OPPORTUNITY.



For Real Job Security—Get an I. C. S. Diploma! I. C. S., Scranton 15, Penna.

Accredited Member.
National Home Study Council

INTERNATIONAL CORRESPONDENCE SCHOOLS



BOX 23513G, SCRANTON 15, PENNA.

(Partial list of 258 courses)

Without cost or obligation, send me "HOW TO SUCCEED" and the opportunity booklet about the field BEFORE which I have marked X (plus sample lesson):

ARCHITECTURE and BUILDING

- CONSTRUCTION**
- Air Conditioning
- Architecture
- Arch. Drawing and Designing
- Building Contractor
- Building Estimator
- Carpenter Builder
- Carpentry and Millwork
- Carpenter Foreman
- Heating
- Painting Contractor
- Plumbing
- Reading Arch. Blueprints

ART

- Commercial Art
- Magazine Illustration
- Show Card and Sign Lettering
- Sketching and Painting

AUTOMOTIVE

- Automobile
- Auto Body Rebuilding and Refinishing
- Auto Engine Tuneup
- Auto Technician

AVIATION

- Aero Engineering Technology
- Aircraft & Engine Mechanic

BUSINESS

- Accounting
- Advertising
- Business Administration
- Business Management
- Cost Accounting
- Creative Salesmanship
- Managing a Small Business
- Professional Secretary
- Public Accounting
- Purchasing Agent
- Salesmanship
- Salesmanship and Management
- Traffic Management

CHEMICAL

- Analytical Chemistry
- Chemical Engineering
- Chem. Lab. Technician
- Elements of Nuclear Energy
- General Chemistry
- Natural Gas Prod. and Trans.
- Petroleum Prod. and Eng.
- Professional Engineer (Chem)
- Pulp and Paper Making

CIVIL ENGINEERING

- Civil Engineering
- Consulting Engineering
- Highway Engineering
- Professional Engineer (Civil)
- Reading Shop Blueprints
- Sanitary Engineer
- Structural Engineering
- Surveying and Mapping

DRAFTING

- Aircraft Drafting
- Architectural Drafting
- Drafting & Machine Design
- Electrical Drafting
- Mechanical Drafting
- Sheet Metal Drafting
- Structural Drafting

ELECTRICAL

- Electrical Engineering
- Elec. Eng. Technician
- Elec. Light and Power
- Practical Electrician
- Practical Electrician
- Professional Engineer (Elec.)

HIGH SCHOOL

- High School Diploma

GOOD ENGLISH

- Good English
- High School Mathematics
- High School Science
- Short Story Writing

LEADERSHIP

- Industrial Foremanship
- Industrial Supervision
- Personnel-Labor Relations
- Supervision

MECHANICAL and SHOP

- Diesel Engines
- Gas Elec. Welding
- Industrial Engineering
- Industrial Instrumentation
- Industrial Metallurgy
- Industrial Safety
- Machine Shop Practice
- Mechanical Engineering
- Professional Engineer (Mech)
- Quality Control
- Reading Shop Blueprints
- Refrigeration and Air Conditioning
- Tool Design
- Tool Making

RADIO, TELEVISION

- General Electronics Tech.

INDUSTRIAL ELECTRONICS

- Industrial Electronics
- Practical Radio-TV Eng'g
- Practical Telephony
- Radio-TV Servicing

RAILROAD

- Car Inspector and Air Brake
- Diesel Electrician
- Diesel Fuel and Fireman
- Diesel Locomotive

STEAM and DIESEL POWER

- Combustion Engineering
- Power Plant Engineer
- Stationary Diesel Eng.
- Stationary Fireman

TEXTILE

- Carding and Spinning
- Cotton Manufacture
- Cotton Weaving and Weaving
- Loom Fixing Technicians
- Textile Designing
- Textile Finishing & Dyeing
- Tinting
- Weaving and Weaving
- Worsted Manufacturing

Name _____ Age _____ Home Address _____

City _____ Zone _____ State _____ Working Hours _____ A.M. to P.M. _____

Occupation _____ Canadian residents send coupon to International Correspondence Schools, Canadian, Ltd., Montreal, Canada. . . . Special low monthly tuition rates to members of the U. S. Armed Forces.

DOUBLE ACTION WESTERN

VOLUME 26

August, 1959

NUMBER 6

● *The Story of Clay Allison — Sheriff Killer*

FEET OF CLAY *John Harrison McLean* 54

He was a real bad man — a gent who liked trouble and went out looking for it. A man who enjoyed killing, and never missed an opportunity to add to his tally stick.

● *Action-Packed Novel*

OUTLAWS OF DUST CANYON *Saul Anthony* 6

Tex Lonergan had never seen this girl until he barged into her room while trying to escape Casson and his killers. But when she learned that Tex was looking for Steve Barlow, Caroline was ready to fight by his side — against her own brother!

● *Short Stories*

IMPOSSIBLE ESCAPE *Richard H. Burgess* 69

Recent discoveries in Texas have shown that this story is not as "impossible" as it seems. So just imagine that you are reading the true account of two women who escaped from the Alamo...

DEADLANDS JUSTICE *Elton Webster* 91

Ashley was ready to pay Witchitaw a high price for trapping the king of the wild stallions — and Witchitaw didn't know why...

CONFIDENCE *Art Cleveland* 108

I was sure I had a winning hand — but my dinero was gone now...

TALK TO A KILLER *J. J. Mathews* 114

Pistol Pete was twice as dangerous holed up as he was out in the open. But if he could be persuaded to surrender and guaranteed a fair trial...

Editor: ROBERT A. W. LOWNDES

MARIE A. PARK, Asso. Ed.

DOUBLE ACTION WESTERN, August, 1959, published bi-monthly by COLUMBIA PUBLICATIONS, INC., 1 Appleton Street, Holyoke, Mass. Editorial and executive offices at 241 Church Street, New York 13, N. Y. Entered as second class matter at the Post Office at Holyoke, Mass. Single copy 35c; yearly subscription \$2.00. Printed in the U. S. A.

WHAT SECRET POWER DID THIS MAN POSSESS?

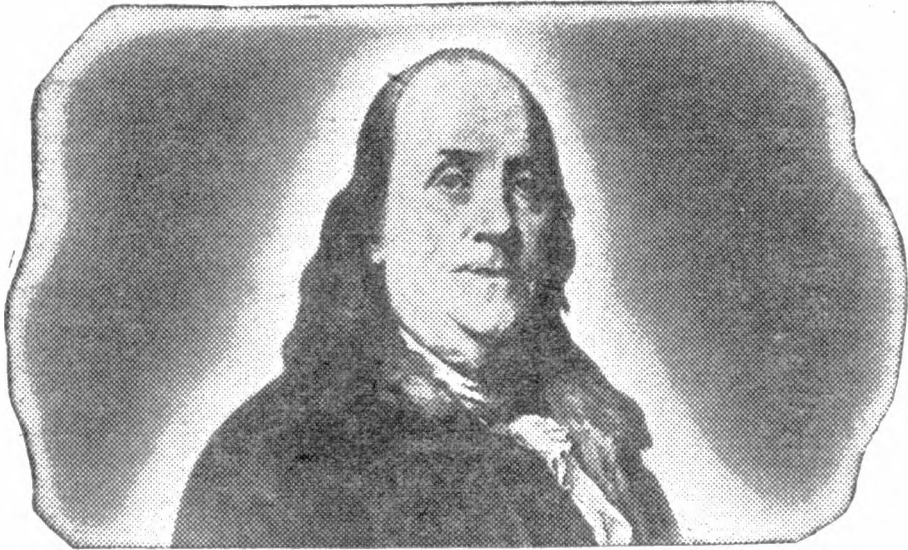

BENJAMIN FRANKLIN (A Rosicrucian)

WHY was this man great? How does anyone—man or woman—achieve greatness? Is it not by mastery of the powers within ourselves?

Know the mysterious world within you! Attune yourself to the wisdom of the ages! Grasp the inner power of your mind! Learn the secrets of a full and peaceful life! Benjamin Franklin—like many other learned and great men and women—was a Rosicrucian. The Rosicrucians

(NOT a religious organization) first came to America in 1694. Today, headquarters of the Rosicrucians send over seven million pieces of mail annually to all parts of the world.



THIS BOOK FREE!

Write for YOUR FREE COPY of "The Mastery of Life"—TODAY. No obligation. No salesmen. A non-profit organization. Address: Scribe **E.S.X.**

The ROSICRUCIANS

SAN JOSE • (AMORC) • CALIFORNIA

SEND THIS COUPON

Scribe **E.S.X.**

The ROSICRUCIANS (AMORC), San Jose, California

Please send me the free book, *The Mastery of Life*, which explains how I may learn to use my faculties and powers of mind.

NAME _____

ADDRESS _____

CITY _____

ZONE _____

STATE _____



OUTLAWS OF DUST CANYON

Complete Novel

by Saul Anthony

The trouble started when Tex Lonergan asked this stranger about Steve Barlow, the man Tex was trying to find. And it led him to a girl who was willing to fight on the side of a stranger, because she wanted Barlow, too!

A HARD DAY in the saddle was nothing new to Tex Lonergan. He had been wandering almost since he was first able to sit astride a horse, with his dad in those days, for old Martin Lonergan had seemed afraid to stay in the one place too long lest he take root there. Then when the old man had passed

on, Tex had worked the grief out of his system by keeping on the move.

When he found a town he liked he might stay a month or two but when he tired of it he would be off again. He was twenty now, but he still felt the urge to suddenly throw up everything, slip into the saddle and head for new country.



Caroline kicked the gun away, just as Casson was getting his fingers on it...

"Mebbe I'm too hard to please, or somethin'," he would say when folks asked why he was going. "Mebbe there jus' ain't anythin' I like well 'nough to keep me here."

But not so long ago he had found something he liked in the little Wyoming town of Green Hills. That was where he had first met up with Lois, when he had taken a sock at a cocky youngster who had bothered her in the street one day. Inside of a couple of weeks he was a regular visitor to the little Barlow ranch, where Lois lived with her father.

At old Barlow's suggestion he had stopped at the ranch and helped out in the busy season and had soon become almost one of the family. Almost, but not completely; but he meant to attend to that little matter when he got back to Green Hills.

As he slid from the saddle outside the Border Saloon, he checked the twin forty-fives at his hips, then hitched the horse to the rail. From inside the saloon came the usual saloon noises—rowdy chatter, raucous laughter occasionally, and

through it all the tinny notes of an ancient piano.

His mind was on Lois as he pushed through the swing doors and sauntered across to the bar. Funny how he had roamed the country for so long without finding anything worthwhile, then the moment he found Lois he had had to leave her.

Sure, he would be back in Green Hills in no time and then he could ask Lois that simple little question. Trouble was that he had been telling himself that for quite a few weeks now, and each week was finding him further and further from the Barlow spread.

But a promise was a promise—to Tex, anyway. Lois understood, of course, but a gal could get lonesome, couldn't she? There were plenty of young chaps in and around Green Hills, some of them mighty fine chaps, too.

HIS EYES took a little time to accustom themselves to the light and the smoke-laden atmosphere of the saloon, but he edged his way through the crowd at the bar in order to do something for his parched

throat. In four hours crossing Dust Canyon he had come to appreciate how well it had been named; but after his third drink he felt that some of the dust at least had been washed away, and he turned to survey the scene.

Would this be just another town like all the others he had visited in the past few weeks, or would this be the end of the trail? Maybe here in High Water he would find young Steve Barlow. He hoped so. He felt that he had already wasted more than enough time looking for that no-good brother of Lois, but Tex had promised her father that he would find Steve and bring him back home, and that was what he intended to do. The old man had known the end was near and it was only natural that he would want his son to take over the ranch when he was gone.

Tex's keen eyes scanned a lot of the faces in the saloon, then he strolled casually among the tables to make sure he didn't miss anybody. In the past few weeks, he had looked at a lot of faces, spoken to many people and asked a lot of

questions without so far getting a scrap of information about young Steve.

Most of the men at the tables were too busy with their poker games even to notice Lonergan, but at one table it caused trouble. Four men were playing cards and the one who had his back to Tex was tall and slightly built and had the same kind of sleek black hair as Steve Barlow. Tex's eyes lit up as he spotted the man and he moved quickly around the table for a closer look. As he did so the man looked up. The excitement faded as Tex realized that this was not Steve and was in fact a much older man.

"Lost somethin', son?" demanded the man in a voice that was far from friendly.

"I was lookin' for a friend," replied Tex. "You ain't him."

The dark-haired man scowled, possibly suspecting some well-hidden sarcasm in the youngster's last remark.

"You ain't gonna find any by bein' nose-y." he snapped.

It was the best reply he could think of at the moment and though it did not fit the situation particularly well, his

three companions obliged by sniggering. Tex smiled. The man's tone had been offensive, but Tex was never one to seek trouble, especially in a strange town; he went to move on to another table.

"Who's this friend you're lookin' for?" the man asked, and Tex turned back.

"Cocky young hombre by the name o' Steve Barlow," drawled Tex.

TEX HAD asked so many people about Steve that he had become used to either a shake of the head or an apologetic smile, but he got neither from the tall man.

He got no reply at all, but his keen eyes did not fail to detect the swift exchange of glances between the four men. It was all over in a fraction of a second, but Tex had seen enough to know that, at last, he had found someone to whom the name of Steve Barlow meant something.

"I see you know my friend," said Tex. "If you'd jus' tell me where I could find him I'd be much obliged."

The tall man had put down

his cards when he had first spoken to Lonergan, but now he picked them up again and began studying them in a way which suggested that his conversation with Tex was at an end. As far as Tex was concerned, however, it was **only** just starting.

"I got an idea you know young Steve," he said again. "If you'd tell me where he lives, or where he works, or where I'd be likely to find him, you'd be helpin' a lot."

The tall man continued to ignore him and there was a chorus of chuckles not only from the other three men at the table but also from others nearby. Tex did not see the joke. So far he had spoken civilly to the man, despite the fact that he had taken an instant dislike to him. But Tex was no more patient than the next man, and when it came to being ignored and laughed at he reacted as most men do.

"Let's give the fellas some-thin' better'n this to laugh at," he snapped; as he spoke, he hooked his foot around the rung of the man's chair and pulled it towards him. It caught

the tall man completely by surprise and he was unable to prevent himself being tipped off. He sprawled on the floor and Tex kicked the empty chair on top of him. Whether the sight of the dark-haired man struggling to regain his feet amused the crowd or not was hard to say, but they did not laugh.

A breathless hush descended on the crowded saloon and those nearest the table at which the trouble had started edged their way back a little. Tex stood looking down at the tall man, but he was also on the alert for a move by any of his three friends.

"That was mighty clumsy o' you, son," said the dark-haired man as he got to his feet. "Leastwise I think it was jus' clumsiness. If I thought you done it on purpose I'd give you a lesson, in spite o' the fact that the marshal jus' walked in."

TEX HAD been surprised that not one of the men had gone for his gun; but apparently all four had seen the arrival of the marshal and were not prepared to tangle with him, at

least in such a public place.

"What's goin' on here?" asked the marshal, shouldering his way through the crowd and looking from Tex to the grim-faced man. As nobody attempted to enlighten him he turned his attention to Lonergan. "Ain't seen you 'bout before," he said. "I'm askin' what's goin' on?"

"Jus' talkin'," drawled Tex.

"Not too friendly by the look o' things," said the marshal. "Reckon I jus' walked in in time. A few seconds later an' I reckon there'd been a bit o' lead flyin' 'round. Ain't that so, Casson?"

"Ain't never been no good at lookin' into the future, marshal," replied Casson tightly. "Don't know how this stranger feels 'bout it. Reckon he can't see into the future, though; otherwise he'd be lookin' a mite worried."

The marshal looked at Casson sharply.

"That some sort of a threat?" he demanded. He turned to Tex again. "You're welcome in this town, stranger," he said. "Leastwise, until you make trouble."

"Fair 'nough," drawled Tex. "Ain't aimin' to start any, ain't aimin' to dodge any, either. See you 'round, marshal."

Without waiting for an answer Tex turned and made his way slowly back to the bar. Men moved out of his way as he walked in silence, but as he breasted the bar counter things began returning to normal. He found the barkeep looking at him with interest.

"Some guys take poison, some guys drown 'emselves," said the barkeep.

"I know," said Tex. "Give me a drink!"

"Other guys pick a fight with Slim Casson," continued the barkeep. "Guess that's as good a way as any."

"There is a quicker way," drawled Tex. "You can talk funny when a man wants a drink."

The barkeep grinned and put bottle and glass on the counter.

"Jus' my way o' tryin' to let you know you've jus' tangled with someone who don't like bein' tangled with," he said. "You bein' a stranger in High Water, an' all."

"T h a n k s," said Tex.

"Mighty nice o' you to be so thoughtful."

"Gotta try to keep my customers happy," grinned the barkeep. "An' if I can't keep 'em happy, at least I try to keep 'em."

"What's this Casson hombre do 'round here?" asked Tex as he helped himself to a drink. "Between killin's I mean."

THE BARKEEP was wiping a glass and he looked up sharply.

"I didn't say he was a killer," he said. "What're you tryin' to do, get my job?"

Lonergan swallowed his drink and poured out another. He smiled. "Let's drop the funny talk, huh? What's this Casson fella do?"

"Got some business interests in the town or somethin'. I believe," replied the barkeep. "Don't know exactly what they are. Seems to have plenty o' paddin' in his wallet, though."

"Ever hear of a guy named Steve Barlow?" asked Tex, watching the barkeep's face for any sign of recognition.

The man's face showed nothing to indicate that the name

meant anything to him. He shook his head. "Can't say I have. Is that the hombre you're lookin' for?"

"Who said I was lookin' for anyone?" asked Tex, smiling again.

"Don't see any other reason for anyone to come to a town like this," replied the barkeep.

"Is it that bad?" asked Tex.

"Yeah!" came the reply.

"Unless o' course you're goin' on south to the cattle country. Good country down there. But to come through the Canyon, get to High Water an' jus' stop is kinda silly. Unless, as I say, you're lookin' for somebody."

"O.K.!" said Tex. "So I'm lookin' for a young fella called Steve Barlow. He's a mighty hard fella to track down. Every place I go I ask 'bout him an' nobody knows anythin' 'bout him. But I know he's been here. Reckon he might still be here. Guess I'll go get me some sleep. I've been ridin' all day an' I'm tired, but in the mornin' I'm gonna go through this town until I find him or find out somethin' 'bout him."

"Do that," said the barkeep. "But don't sleep too sound.

You've made a mighty dangerous enemy tonight. An' tomorrow, when you're goin' through the town keep your eyes peeled; but don't tell anyone I told you."

II

AS TEX LONERGAN neared the door he glanced in the direction of Casson's table and smiled grimly as he saw four pairs of eyes hastily lowered. He had not needed the barkeep's warning to realize that Casson and his friends would be planning revenge. He knew Casson's type well. They were to be found in almost any western town. Always plenty of money, and plenty of gunslingers to take care of anyone who got in their way.

He left the saloon and hurried along the boardwalk to a nearby doorway and stepped into the shadows. Then he watched the door of the saloon. He had not long to wait before he saw four men leave the saloon, two of them coming in his direction and the others going the opposite way.

He pressed back into the shadows as the two men approached. They were hurrying along and talking as they came. When they were opposite his doorway he slid his hands down to his guns, but did not draw.

"You've come far 'nough, boys," he drawled.

There were muttered exclamations from the two men as the calm voice reached them. They stopped.

"Leave your guns where they are an' jus' listen," Tex went on. "I don't like bein' followed. It has a bad effect on me. My nerves go all to pieces an' I start shootin' all over the place. You wouldn't want me to do that, would you, boys? Not with me bein' here in the dark where you can't see me, an' you bein' out there in the street where there's 'nough light for me to see you. Take my advice an' go straight back to the saloon an' stay there for half an hour. While you're there you can tell Casson he's gonna talk next time I see him."

One of the men cursed.

"You got the drop on us, mister," he said, "but it ain't always gonna be so. If you're

figgerin' on gettin' tough with Casson, I'd think it over first if I was you. Slim don't like bein' treated like you treated him tonight."

"So I've heard," said Tex. "Now get back to the saloon. Give Casson my message an' keep outa my way."

The two men went and Longergan did not emerge from the darkened doorway until he saw that they had re-entered the saloon. Then he hurried on down the street in the direction of a lodging-house he had noticed when he had arrived.

H HE HAD TO haggle a little to get a room, but the sight of his money soon brought results and he went upstairs and threw himself on the bed. He had had a hard day altogether, and the only thing which interested him at the moment was a good night's sleep. He intended to do the rounds of the town next morning as he had done in every town he had visited during his search for young Steve. But in High Water there was this difference, that he was sure that Slim Casson at least knew of Steve. If

Lonergan could find nobody else who could give him any information he would not hesitate to get it out of Casson, by force if necessary.

He dozed, but for how long he did not know. Suddenly he sat up. He was wide awake and listening. He felt that tingling feeling that one always gets at the feeling that somebody else is in the room. It must have been the creak of the door which had awakened him. All was silent, but his hand stole quietly beneath the pillow and closed around the handle of a forty-five.

He was glad he was just lying on the bed, and was not hampered by any bedclothes. He began to doubt whether he had really heard anything, but there was only one way to find out. With a gun in one hand he grasped a corner of the pillow with the other and hurled it at the door.

He figured that if there was an intruder in the room, and it had been the sound of the closing door which had awakened him, that intruder would not yet have moved very far from the door. As the pillow thudded

against the door there was a startled exclamation and the instant he heard it Tex fired.

As he fired he dived from the bed on to the floor, for if the intruder returned the fire he was likely to aim at the position of the gunflash. But instead of a return fire there came a cry of pain and the sound of a gun falling to the floor. The two noises were enough to give Tex a pretty good line on the intruder's position in the room and he hurled himself at the spot where he judged him to be.

The room was in absolute darkness and it was just a chance leap. Tex's judgment proved correct, but as he landed on top of the man he winced as his chin made violent contact with the man's boot. It jarred his whole face and neck, but he managed to keep his mind on his job and his fingers sought a grip on the prowler.

Tex's strong hands closed around the man's neck, but he was off balance and failed to retain the grip as his assailant managed to slide from beneath him. Tex judged him to be a

man of very powerful build and he realized that he had a real fight on his hands. And it was a fight he must win, for if this was one of Casson's men—and he had no doubt it was—then he was there for the express purpose of killing Lonergan.

But there was one thing which might make it easier for Tex, and that was the fact that he had heard the man cry out as though wounded. Possibly it was only a scratch, but it might handicap him enough to turn the tide Tex's way. Both men scrambled to their feet.

TEX'S EYES had now become a little more accustomed to the darkness and he could see his enemy silhouetted against the window and the pale light from the sky. He lunged forward, making the most of his advantage and his fist crashed hard into the man's face.

Quick to follow up, Tex let fly with another terrific punch, this time at the man's body, and there was a grunt as it found a target. The intruder staggered back, winded, and as Tex came at him again he real-

ized that his assailant was fighting with one hand only. It looked as though Tex had indeed winged him with that lucky shot.

Tex pounded away at his enemy and the man could offer very feeble resistance. Time and again Tex crashed his fist to face and body and finally the man went down. He tried to struggle to his feet again, but Tex did not give him time to become properly balanced before he put all he had into a blow at the man's jaw.

With a groan the would-be assassin staggered back again, then slumped to the floor and lay still. Breathing heavily, Tex stood where he was for a few seconds, alert lest the man be shamming. Then, satisfied that he had nothing to fear for a few minutes at least, he turned to a small table against the wall and lit the lantern.

By its flickering light he could see that Casson's man was out cold, and he crossed to the corner of the room where his gear lay piled on the floor and took a length of rope. He rolled the man over face down and tied his hands securely,

then ran rope down his back and knotted it about the ankles.

There was fresh blood on one of the man's sleeves and Tex ripped the cloth but found it was only a slight flesh wound. As he bent over the man he saw the eyes open. The bound man tried to get to his feet, but could scarcely move.

"Save your strength," drawled Tex, straightening up. "You one o' the guys who came gunnin' for me earlier in the night?"

The man didn't answer.

"If you are, you'll see the kind o' thing that's gonna happen to you when you don't heed my warnin's," said Tex. "Seems like Casson's got a lot o' simple guys to call on to do his dirty work. Some day you critters are gonna realize that Casson gets the dough and you mugs get the danger."

The man again tried to struggle to his feet, but in vain.

"Better make yourself comfortable," said Tex. "You're gonna stay there until the mornin'. Don't see no sense in lettin' you go now to tell Cas-

son to send a couple more o' his gunslingers up here to get me."

Tex got a second length of rope from his saddle in the corner, cleared the things off the small table, then rolled the man over face down again, and none too gently. Then he turned the table upside-down, placed it on the man's back and tied it securely to his body.

A string of oaths greeted him, but he merely smiled.

"That's jus' so I'll hear you if you move too much," said Tex. "I've gotta get some sleep now."

He crossed to the door and turned the key in the lock, then slipped the key into his pocket. He realized that he had been foolish not to have locked the door in the first place.

He left the lantern burning beside the bed, then threw himself down and was soon sound asleep. The table, though only small and light, had eliminated any slight chance his prisoner may have had of getting on his feet again, at least without making such a clatter as to awaken Tex.

III

"I FORGOT to tell Rocky to come let me know how he got on," said Slim Casson testily. "Looks like I've gotta give you critters written instructions."

The other two men in the room said nothing. With Slim in his present mood, nothing was the only thing it was safe to say. Casson glared at his companions as he spoke. It was late in the evening and the three were waiting on the outskirts of the town for Rocky to return from his mission.

"Mebbe somethin' went wrong," ventured Ty Garnsey.

"No reason why it shouldn't," snapped Casson. "I seem to have 'round me the biggest lot o' fools any man ever had. All Rocky had to do was wait until the guy was asleep, then pump a bit o' lead into him. Rocky'd probably end up in the wrong room anyway."

Ty Garnsey grunted. He did not follow a policy of criticising his leader, but Rocky was a particular friend of his. He had taken the troublesome stranger

to be a man who knew how to take care of himself, and he realized that Rocky's task might not be as easy as Casson made out.

"This hombre who made you look a monkey tonight ain't no fool," he said. "Mebbe Rocky couldn't get to him, or mebbe the guy was waitin' for him, like he was waitin' in that doorway for Sam an' me."

"Look, Ty," said Casson. "In the first place this hombre didn't make me look a monkey tonight in the saloon. If the marshal hadn't walked in when he did, we wouldn't be worryin' 'bout the critter now."

"You might be right there," growled Ty. "Only not the way you think."

Slim Casson ignored the remark and went on. "In the second place, if Rocky did as he was told, it was easy."

The third man spoke for the first time. He was small and wiry, with a hooked nose and small beady eyes.

"We gonna wait here all night for him?" he asked. "We'll hear all 'bout it in the mornin', won't we? If he took care o' the stranger it'll be all

over town, an' if Rocky bungled it an' got a bellyful o' lead we'll hear 'bout that, too."

"You're so right, Sam," said Casson, glaring at the little man. "Only thing is we was gonna be outa town tomorrer, but if this hombre's still 'round we'll have to have another try. He's too nose-y to leave loose in High Water. I ain't given you a killin' job for quite a while, so mebbe you'll get your chance tomorrer."

A look of alarm spread across Sam's face and he colored as the other two laughed.

"I ain't scared, if that's what you're thinkin'," he growled. "If Ty's so worried 'bout Rocky, why don't he go see what's happened to him?"

"Reckon I will," said Ty, becoming serious again.

"Reckon you won't," snapped Casson. "Ain't you guys got any brains at all? If anythin's happened to Rocky, don't you think this trouble-maker will be on the alert for a second visitor? We'll wait until mornin', then if the stranger's still alive I'll take care o' him myself."

THEY LEFT it at that, and the meeting broke up. Sam and Ty left Casson's room, Sam to go home to bed, but Ty had other plans. He waited until Sam had disappeared down the street, then turned in the direction of the lodging-house where they knew Tex Lonergan had registered. It had been a simple matter to track the stranger down, for landlords—like most people in High Water—readily gave information to Casson.

Ty Garnsey approached the building cautiously, but it was getting late and there were few people about. He slipped inside and went quietly upstairs. He had been present when Casson had given Rocky his instructions, and he knew which was Lonergan's room.

When he had reached the top of the flight of stairs he hesitated. He had come to see what had happened to his friend, but now that he was there he was undecided on a course of action. The door of Lonergan's room was closed, and Garnsey realized that it might be locked if Rocky had

failed to get his man. It was a ticklish position.

It was no good trying to enter the room by force, for if Rocky had failed and the alarm had been given, Lonergan would undoubtedly be prepared for trouble. He tried the door, but could not open it. Then Garnsey remembered that there was a balcony running along the outside of the upstairs rooms and thought it the best point from which to take the occupant of the room by surprise.

At the end of the passage he found an unlocked door, slipped inside the room which appeared to be used as a box-room, and climbed through the window on to the balcony. He reached the window of Lonergan's room and peered inside. What he saw made him draw a deep breath, although the sight of Rocky with the table tied on top of him brought a faint smile to his lips.

Rocky had apparently bungled the job, as Casson had suspected, but he would soon put things right. He found the window unlocked and raised it slowly and silently. The lan-

tern was burning in the room and Lonergan was on the bed in the center of the room, apparently asleep.

"Certainly a cool hombre, this," Garnsey muttered. "A guy comes to kill him an' he jus' ties him up and goes to sleep again."

But Lonergan was not asleep, as Garnsey soon found out as he came through the window and approached the bed. Lonergan was a light sleeper, especially when there was trouble about, and he had not failed to detect the slight noise which the door-handle had made.

WITH THE door locked, an intruder would naturally try the window, and by the time Garnsey had entered the room Tex was ready for him, his hand clutching the gun beneath the pillow.

Garnsey had started to draw his gun as he came through, but he saw Lonergan move too late. Blood spurted from his gun-hand and he cried out in pain. Lonergan was on his feet in an instant and motioned him forward.

"Figured on havin' a room to myself," drawled Tex. "Things are gettin' a mite crowded, but I guess I can fit you in somewhere."

Garnsey was too concerned about his shattered hand to offer any resistance or even think clearly. He seemed dazed that Lonergan could have acted so quickly.

"Gettin' kinda short o' rope," said Tex, with mock apology in his voice. "Guess you'll have to share with your friend. Untie the table, but don't get the funny idea o' untyin' anythin' else, or you'll get it in the back."

Garnsey did as he had been told, although his injured hand hampered him and he took quite a while. Lonergan kept him covered from behind, then used the rope to bind the two men back to back.

"Don't know why I don't pump a bit o' lead into both o' you," said Tex. "But I reckon this'll keep you outa mischief until mornin'. Then I'll hand you over to the marshal."

Garnsey grunted. "You oughta get smart, stranger," he said, "an' get outa town."

Tex smiled. "I seem to be doin' all right so far. I came here for certain information, an' I intend to get it."

"There's a lot more of us yet," replied Garnsey. "Luck's been with you tonight, but it'll be different tomorrer. You ain't gonna see sundown unless you get outa High Water."

"We'll see," said Tex, and he went back to the bed, but not to sleep.

He was tired and it took will-power to stay awake, but at last the first light of dawn showed in the eastern sky. A glance at his prisoners showed that they were still securely tied, and had little hope of escape. He moved about the room cleaning himself up as best he could—partly because he needed it, and partly because it was too early to call on the marshal.

A COUPLE of hours later, he went out, locking the door behind him. He made his way to the marshal's office. The lawman was surprised at the early caller.

"Come to tell me you're leavin' town, huh?" he asked. "Best thing you could do, I

reckon, now that you've run foul o' Slim Casson an' his crowd."

"I'm not leavin'," drawled Tex. "I jus' came to report that I had a coupla callers last night. I've got 'em tied up in my room at the lodgin' house if you wanta come get 'em."

"Did they attack you?" asked the lawman, his face clouding. "I half expected somethin' like this would happen. I ain't a fool, you know, Lonergan. I knew you was in trouble last night. This Casson guy's a guy to keep away from."

"I can see you ain't a fool," drawled Tex. "You know my name, but I don't know how. This ain't a very friendly town. Ever since I got here, folks have been advisin' me to leave. Looks like nobody wants me 'round. I wonder why?"

"Mebbe they don't wanta see you get hurt," said the marshal.

"Mebbe," said Tex.

The marshal frowned.

"You think there's another reason, huh?" he asked. "I get what you're implyin', Lonergan. You're like a lot o' smart

critters who come to this town. Then you think the lawman mus' be crooked too, 'cause he ain't pinned somethin' on him..."

"I didn't say..." began Tex.

"I've heard that tone o' voice too many times not to recognize it," the marshal went on, cutting him short. "You got some private fight with Casson an' you set out to settle things regardless o' what happens to anyone else in the process. You're ready to believe that Casson's crooked, everyone's too scared to do anythin' about him, an' the lawman's crooked. You're all alone, fighting a private fight an' before you know what's happened you've caused the deaths of folks who only want to be left alone."

TEX LOOKED at the angry lawman in surprise. He had not meant to imply that the marshal was in any way dishonest. In fact, in the saloon the previous night he had judged him to be a straightforward man who had certainly not given the impression of being afraid of Casson.

"You got me wrong, marshal," he said, quietly. "I ain't makin' any accusations against you. As far as makin' trouble's concerned, there ain't no reason for anyone else gettin' hurt in my quarrel with Casson. I'm lookin' for a friend o' mine. Casson knows somethin' 'bout him, but he won't talk. I got good reason for believin' some harm might've come to my friend. If not, why won't Casson tell me what he knows?"

"That's somethin' I can't say," replied the marshal gruffly. "If you think you've gotta stay an' settle your fight with Casson, you'll do it, no matter what I say. What's gonna happen if you meet Casson in the street? Same thing as could've happened last night if I hadn't turned up at the saloon. Shootin' will start, an' if anyone's got the misfortune to stop a stray bullet it's jus' too bad. Some good woman's husband'll be dead, but that won't matter so long as you settle your quarrel with Casson."

"You're talkin' rubbish, marshal," snapped Tex. "Supposin' you saw me kill some-

body on the street, what would you do? Would you let me get away so you wouldn't shoot anybody else by accident? You'd be a punk lawman if you did."

The marshal did not reply, but picked up his hat, fastened his gun-belt and walked towards the door.

"We'll go pick up these two o' Casson's hombres," he said. "You comin' 'long?"

"Sure!" said Tex.

They walked in silence to the lodging-house. Tex thought maybe there was something in what the lawman had said, but what was the alternative? It looked to him that something had happened to Steve and that Casson knew all about it. If he was to keep his promise to the lad's father he must get the truth out of Casson. There was no other way.

Tex unlocked the door of the room, threw it open and walked inside. Then he stopped. The marshal was close up behind him.

"Looks like they ain't here," said the lawman, picking up a length of rope from the floor.

"Must've untied 'emselves somehow."

"Yeah!" said Tex. "An' locked the door after 'em, without a key!"

IV

THE MARSHAL returned to his office and Tex Lonergan set out to go through the town in the hope of finding somebody else who knew about Steve Barlow. He strolled along the boardwalk, calling in at stores, stopping likely-looking men in the street, but always without result.

As he walked, he was on the alert for Slim Casson or anyone else behaving suspiciously. He had no doubt that Casson's crowd would try to put him out of the way as soon as they could. He knew too, that it was unlikely that his enemies would come out in the open to deal with him.

A street corner, a doorway, or an upstairs room might even now hide an intending assassin awaiting his opportunity. As he came out of a store after one more futile questioning he

met Duff Colton, the barkeep from the Border Saloon. Colton did not stop, but as he passed Tex he muttered, "Casson's gunnin' for you."

He dropped a coin on the boardwalk as an excuse to linger and while he picked it up, continued, "He's on the street, but you're covered from both sides upstairs. One in a room above Andrews' store, the other on the roof of the telegraph office."

Colton retrieved the coin, slipped it into his pocket, and without so much as a glance at Lonergan continued on his way. Tex leaned against a post to get his bearings. Across the street, maybe a hundred yards further up was the telegraph office. He looked along on his side of the street and drew a deep breath as he found himself not more than twenty paces from Andrews' general store. By staying under the cover of the awnings he could nullify the danger from one side of the street.

He wondered whether Casson would have the nerve to meet him face-to-face. If so, Lonergan was prepared for

him, but it was not the way he wanted it. If he met Casson and Casson went for his gun Tex would have to shoot him. That would, providing Tex beat him to it, remove the danger, but it would do nothing to help him in his search for Steve.

He would have preferred to come across Casson alone somewhere, take him by surprise, and then force him to talk. He turned in the direction of Andrews' store and shot an occasional glance towards the telegraph office. Just how to deal with the situation was difficult to decide, but acting on a hunch he turned in through the doorway of the store.

AN ELDERLY man, probably Andrews, came forward to attend to the customer.

"You own all this building?" asked Tex.

"Yeah!" said Andrews. "Why?"

"There's a fella I wanta see," said Tex. "He's in one o' the upstairs rooms."

Andrews shook his head. "Ain't no one up there."

"Don't lie to me." snapped Tex, his face hardening. "You know there's one o' Casson's hombres up there, an' you know why he's there, too. I'm goin' up!"

The elderly man pulled open a drawer in the counter, but Tex was way ahead of him. With one hand on the counter he swung himself across and cannoned into Andrews, sending him reeling against the shelves at the back.

"Don't be silly, now, Pop," said Tex. "Keep outa this an' you won't get hurt. You're scared o' Casson, I guess, like everyone else, but don't buy into this private fight. I don't wanta hit an old guy like you, but I've got my hands full without you."

"O.K. son." said Andrews hastily. "I ain't gonna make trouble. It don't pay not to do what Casson tells you, though. But I don't wanta help him kill you, an' I don't wanta get hurt, either. All I wanta do is be left alone."

Tex looked at the old man and his face broke into a pleasant grin. "You won't get hurt, Pop," he said.

He turned and ran across the store towards the stairs.

"Which room?" he asked as he ran.

"There's only one," replied Andrews.

Tex took the stairs two at a time. Already he was beginning to understand what the marshal had meant. If Andrews had got his hands on that gun...

When he reached the top he found that Andrews had spoken the truth, for there was only one door. Tex did not hesitate; he was relying on surprise. He had to act before the gunman could realize that Longergan was no longer on the street below, or receive a signal from the man on top of the telegraph office, who would most likely have seen him enter the store.

The door was open an inch or two and Tex shouldered into it, drawing both guns as he did so.

"Drop it!" he snapped.

The gunman kneeling at the window whirled around in surprise, bringing up the rifle. Gunfire crashed and echoed in the small room. Tex fired both

guns together and Casson's man caught one in the arm and another through the chest. He was beaten for speed and the shot from his rifle went wide and high as he pulled the trigger, then pitched forward. As he fell he clutched a hand to his chest, then lay still with the blood spreading down the front of his shirt and through his fingers.

Tex holstered his guns and crossed to the window and looked down to the street below. The gunfire from the upstairs room had attracted attention of the many people in the street and several were looking up at the window. Tex drew back a little so as not to be recognized, then cursed as he saw the marshal, and a couple of other men running across the street in the direction of the store.

Tex had shot a man who had been lying in wait for him, but this was no time to wait for the marshal and argue with him on that point. He had killed a man and even if he were eventually cleared of a murder charge—which was by no means certain—he could

not afford the delay of questioning, probably being arrested and going through his trial.

The best thing to do was to make himself scarce and although the marshal would know who had done the killing, he would have no proof. There was the danger that Andrews might reveal who had been in the upstairs room, of course, but that could not be helped.

HE TURNED toward the door, but as he reached it he heard the sound of men and voices at the foot of the steps and turned back. The window was the only means of escape, and he climbed through and dropped on to the awning some four or five feet below.

The awnings ran in an uneven, but unbroken line almost to the end of the street, and Tex figured that if he could reach the end quickly enough he should be able to drop down, run up a side street and eventually lose himself among the various alleyways on the outskirts of the town.

But as he clumped along the awnings Lonergan realized sud-

denly that he was in danger of being shot at by the man on the roof of the telegraph office across the street.

No sooner had the realization of his danger come to him than a rifle cracked and the bullet thudded into the timber of a building just ahead of him. He threw a couple of wild shots at the man on the roof, but firing as he ran his aim was no good. The man returned the fire, but moving as he was along the varying heights of the awnings he made a difficult target.

He heard shouting in the street below and looked down to find that a great crowd of men were running with him, and some were even a little ahead of him. It looked as though they would reach the end of the street before he did.

He was in a tight spot and the only way of escape now seemed to be to go through a window somewhere in an effort to elude his pursuers. A couple of shots came from among the crowd in the street, and he looked down again. He cursed as he saw the tall, lean figure of Slim Casson now at

the head of the crowd and firing at him.

It was a golden opportunity for Casson, who had probably given the alarm that the fleeing man was a murderer, and was now taking advantage of it to kill Tex Lonergan legally. Not only that, but he was encouraging others to shoot, too. Tex had to do something quickly, and he stopped at a window, threw it open, and climbed inside.

AS HE STEPPED inside, the door flew open and a girl appeared in the doorway. She cried out in amazement as she saw Tex and he drew a gun and pointed it at her.

"Take it easy, kid," said Tex. "You ain't gonna get hurt."

"What are you doing here?" the girl demanded.

"Ain't you heard the rumpus?" asked Tex. "It's kinda dangerous out there on the awnings. A guy might slip an' get hurt."

"Not to mention bullets," said the girl with a faint suggestion of a smile playing

about her lips. "What have you done, killed somebody?"

"Yeah!" said Tex, watching the girl's face, but she did not seem shocked, or even surprised. "One o' Casson's men."

"Oh!" said the girl. "In that case they should be chasing you to thank you, not shoot you."

"You don't like Casson, huh?"

She was an attractive girl, with good features and shining black hair. She tossed back her head and smiled again. "He's an evil man, and so are the rest of his crowd. I have good reason to know."

"So I've noticed," said Tex. "Anyway, there's gonna be a whole crowd o' fellas, good and bad comin' up here any time now. Where can I hide?"

"There's a cupboard out in the passage," she replied. "It's only small, in fact so small that they won't think of looking in there. It'll be a bit cramped, but I think you could squeeze inside."

"O.K." said Tex, moving to the door. He was not sure yet whether he could really trust the girl. Maybe she was play-

ing friendly just to get him out of her room and would tell the men where to find him. However, he had so little time that it was a chance he must take.

At the doorway he stopped. The mob had already entered the building, and it was doubtful if he could get into his hiding place before they came up the stairs.

"Too late," said the girl, pulling him back into the room. "Get under the bed. I'll get rid of them."

Tex did as the girl said. There was nothing else he could do.

He slid under the bed and the girl carefully re-arranged the spread which reached almost to the floor. Then she dropped to the floor on her hands and knees, and just appeared to be getting up as the mob surged in at the open doorway.

Slim Casson was at the head of the crowd, and with a muttered exclamation he rushed forward to help her up.

"Caroline!" he exclaimed, as he helped her to her feet and she stood, swaying uncertainly

in his arms. "Caroline! Are you all right? Did that hombre knock you down?"

"Oh!" cried Caroline. "That awful man! He came through the window with a gun in his hand. He punched me!"

She began to sob, and Tex, from his hiding place under the bed, marvelled at the way she was putting it over.

"Where did he go?" asked Casson.

"I don't know," snapped Caroline, feigning a kind of hysterical annoyance. "He knocked me down and rushed across the room and out through the door. I don't know where he went and I don't care."

Once the information was out, Casson did not waste any further time in trying to comfort the girl. He spoke gruffly to the crowd in the doorway and then surged outside again. When they had all gone Caroline closed the door. She waited until they had apparently finished searching the other rooms and she heard them tramp down the stairs again. Then she lifted the spread and called Tex out.

"They've gone," she said. "How was my act?"

"Not bad at all," said Tex, grinning. "You put it over good 'nough to convince anyone. You fooled Casson, all right. Matter o' fact, you saved my life."

"Only temporarily," drawled Slim Casson, standing, gun in hand, at the door.

V

TEX LONERGAN had been standing with his back to the door and he had also hidden the doorway from the girl's view. They both whirled around at the sound of the outlaw's voice, but Tex kept his head and did not go for his gun.

"Had an idea you might've been puttin' on an act," said Casson. "You fooled the others O.K., but you can't fool your good-lookin' brother."

"Brother!"

The word snapped out from between Tex's tight lips. He looked from one to the other and the color deepened in his face.

"Casson's your brother?" he demanded.

"Yes, he's my brother," snapped the girl. "There's no need to look at me like that. Can I help it if my parents gave me a rattlesnake for a brother?"

"Don't worry, Lonergan," said Casson with a sneer. "If you're gettin' sweet on Caroline, don't let it turn you off her. She's always been kinda disgusted that her big brother didn't become a respectable storekeeper or somethin'. I'm tellin' you this so you won't think bad of her jus' before you die."

"You can't shoot him in cold blood," cried Caroline in alarm.

"He's wanted for murder," said Casson, smiling an evil smile. "Now, I've captured him, it's my duty to hand him over to the marshal."

The girl was relieved.

"That's all right, then," she said. "The marshal's a fair-minded man. When he finds it was one of your men who's been killed he'll know probably who's to blame."

Casson laughed contemptuously. "Don't get all excited,

Carrie," he said. "I said it was my duty to hand him over to the marshal. I didn't say I was gonna do my duty."

"Then what are you going to do?" demanded Caroline.

"I'm gonna take him downstairs," replied Casson. "On the way down I wouldn't be surprised if he tries to escape. If he does that, of course, I'll jus' have to shoot him."

His meaning was quite plain. On the way down to the street, Tex would get a slug in the back and Casson would report to the marshal that the wanted man had tried to escape and he had no alternative but to shoot him. The marshal would not believe the story, probably, but there was nothing he could do about it.

While he had been speaking, Casson had been on the alert for any desperate escape bid that Lonergan might try to make, but he was not prepared for what happened next. When the meaning of Casson's remark sank into her brain Caroline's eyes opened wide in horror and she threw herself at her brother and pounded away at his chest.

THE BLOWS did not hurt the tall outlaw, but they made him divert his attention from Lonergan for a second, and that second was all that Tex needed. With Caroline blocking the way he could not shoot, but he threw himself against them both. He crashed heavily into the girl and she in turn was thrown hard against Casson.

Tex was quickly around the girl, knocking the gun from the outlaw's grasp. Then he let fly with a hard punch to the man's chest. It was not a decisive blow, but it was sufficient to prevent Casson from retrieving the fallen gun. As Casson staggered back, Tex followed up his attack and his fingers closed around the outlaw's throat.

The two men fell to the floor as Caroline watched breathlessly. Lonergan soon found that his enemy was a powerful man, despite his slim build. With a supreme effort Casson threw Tex off.

While Tex rolled across the floor and tried to scramble to his feet, the outlaw's hand stretched out and he groped

for his gun. His fingers were just closing around the handle when Caroline's foot shot out, kicking the gun away from him and sending it slithering across the room.

Casson cursed in rage and Tex returned to the attack. The outlaw had regained a crouching position as Lonergan reached him and he went over backwards before the youngster's furious onslaught. Tex dived on top of his man, but Casson was able to bring his knee up and it caught Tex in the chest, winding him.

In a moment, Casson had the upper hand and began throwing punch after punch at Tex. Lonergan reeled back under the savage attack. He stumbled against the bed and was unable to stop himself falling back on to it. Casson was on top of him, clutching at his throat. Tex struggled violently, but his feet were entangled in the bedclothes and he found it difficult to break away from the outlaw's strong grip.

He was finding it hard to get his breath and he mustered all his strength in a last desperate effort to break free. He man-

aged to clasp his hands around the outlaw's neck and pull him down closer to him. Then he rolled over suddenly, bringing Casson down on to the bed and at the same time doubling his legs until he had his knees pressed against the outlaw's chest.

Being on his side Casson could not exert as much pressure as he had been able to do while bending over Tex, and with another effort the youngster rolled off the bed bringing Casson crashing with him to the floor. Lonergan managed to land on top and his weight winded Casson badly. The outlaw's fingers released Tex's throat and Tex scrambled to his feet. Both men were feeling the strain, but as Casson got up Tex caught him on the point of the jaw with a terrific right.

Casson went over backwards across the bed and landed in a heap on the far side. As he attempted to rise, Lonergan dived headlong at him and knocked him down to the floor again. The headlong dive, followed by hard contact with the outlaw's chest, jarred Tex's

neck. He shook his head, his vision blurring, and as he did so he heard Caroline scream.

CASSON had made another attempt to get the gun, and Tex Lonergan hurled himself blindly at the outlaw. They arrived at the gun together and collided, shoulder to shoulder. Casson managed to grasp the gun and he turned and fired as he crashed against the wall. The shot was hopelessly wide.

Tex heard the sound of shouting coming from the stairs below and his first thought was that it was probably the marshal, or at least the mob which Casson had been leading. Casson still had possession of the gun. Possibly Tex could have drawn a gun too, and beaten the outlaw to the next shot, but with his mind on the men now running up the stairs, he did the first thing which came into his mind.

He kicked at the outlaw's gun-hand, caught the knuckles square on, and once again the gun clattered to the floor. Tex whirled around as Caroline shouted a warning and saw the

marshal was already at the door with maybe a dozen men behind him. He picked up a chair and hurled it at the doorway and without waiting to see the effect it had, dashed towards the window.

He clambered through and out on to the awning and ran as fast as he could, ignoring the danger of the treacherous, uneven iron. His one aim was to reach the end of the row of buildings and jump down on to the street before any of the men back in the room could get in a shot at him. In a few seconds he had come to the end of the awnings and even as he jumped he heard the bark of several guns. Hot lead passed overhead as he leaped to the road, landed, and rolled in the dust.

He picked himself up and looked about. Already men were running towards him and it was no time to linger. There was a horse tethered to the rail on the opposite side of the street and it offered the best, if not the only chance of escape. He ran across, swung up into the saddle and was soon heading out of town.

He found his borrowed mount to be a good mover and soon became confident that he could shake off any pursuers who might come after him. With the town left far behind he headed for some thickly timbered country away to the north-east.

There was little doubt he would be followed and he had a quick decision to make, whether to take refuge among the trees, or whether to go on and across the canyon to the mountainous country beyond. It did not take him long to decide on the latter course, for undoubtedly it afforded him almost certain escape. At the same time it was a hard ride across the dusty canyon floor.

THE NECESSITY of getting out of town would further delay his search for young Steve Barlow, and after the hue and cry died down he would have to return to High Water and try to beat the information out of Casson. It seemed incredible that nobody else in the town knew of the youngster.

Well out into the canyon he

looked back, but was relieved to find that so far there were no signs of anyone following. He had been able to get away to a flying start, however, and it would take the marshal and his men a while to get to their horses and set out after him.

On his way into High Water he had come along the full length of the canyon, but now, with a hiding place his only immediate objective he cut across in the shortest route to the line of distant ranges. The red dust, raised by the gusty wind, made conditions unpleasant and the hot sun added to his discomfort.

In little more than an hour he had reached the foothills of the range and as he swung around in the saddle to look in the direction of the town he smiled. He had thought as he set out from High Water that he would be visible to the marshal's posse until he had gained the cover of the mountains, but now he realized that the thick red dust, swirling about him as he rode, provided just as good cover.

As he sent the horse up the hills at a steady walk the dust

was at last left behind and beneath was a soft carpet of green grass. He continued the climb for another half-hour, then halted his mount, slipped from the saddle and lay full length in the shade of a big tree to cool off.

No sooner had his head hit the ground than he sat up suddenly. With his head on the ground he had heard the unmistakable sound of horses. It sounded like quite a few horses, too, and near at hand. A posse could surely not have overtaken him so soon.

He listened again, and judged them to be just a little higher up the range and probably heading towards him. His mount had wandered off a little and was contentedly nibbling at the grass, and Tex Lonergan hoped that it would not be spotted by the approaching horsemen. There was little cover on the ground around him and he climbed a tree. Possibly the riders were harmless enough, but it was better not to take chances.

He had not long to wait before the horsemen came into view. They broke through the

trees not more than fifteen yards from him, and Tex counted twelve men. Who they could be he had no idea, but there were some bad looking hombres among them and if ever he had seen a band of outlaws, then this certainly looked like one to Tex.

VI

WHEN THE rest of the crowd had given chase to Tex Lonergan along the awning and up the street, the marshal had stayed behind for a word with Slim Casson.

"You an' this Lonergan fella are sure causin' a lot o' disturbance 'round here, Casson," he said. "What's goin' on?"

Casson had picked himself up and dusted himself and he turned on the marshal with a scowl.

"I was jus' doin' my duty, marshal," he said. "You was after Lonergan for murder. an' I was tryin' to catch him for you. Not that I expect any thanks for it, but I resent you blamin' me. If it hadn't been for Caroline I'd have got him, too."

"Yes, and killed him before he had a chance to tell the marshal what really happened," said Caroline hotly.

"I kinda figured it might be somethin' like that," said the marshal. He turned towards Casson again. "I don't think I need tell you what I think o' you, Casson," he said. "I know there's some sort o' trouble between you an' Lonergan, but if you kill that hombre under any pretext at all, you'll need to have a good story to stop me sendin' you up for murder. The fact that your own sister helps Lonergan to escape shows jus' what kind of a low-down critter you are."

Casson sneered. "So that's your idea o' justice, huh, marshal? You're kinda makin' it hard for me, ain't you? That guy's out to kill me, but you've made it so that if I'm successful in defendin' myself you're gonna hang me for murder. Guess you've been a lawman too long. You're gettin' kinda old for the job. When a lawman starts lettin' personal feelin's interfere with justice, it's time he got out."

The marshal laughed. It was

not often he laughed, and when he did it usually showed his contempt.

"You've been floutin' the law for some years in this town, Casson," he said. "So far you've managed to keep jus' on the right side, but some day you're gonna slip like all your kind. When that happens you'll end up like so many others—strung up, or crawlin' in the dust with a bellyful o' lead. It don't matter whether I'm the lawman or some other guy, if you're plannin' to put me out o' the way."

The marshal turned on his heel and strode from the room. Lonergan was at large, and it was his duty to take a posse and go look for him. In staying behind he had lost valuable time, but he had felt it as well to let Casson know just how things stood.

BACK IN the upstairs room, as the door closed on the lawman, Slim Casson turned on his sister.

"What's the idea o' helpin' that Lonergan hombre get away?" he demanded. "You gettin' sweet on him or some-

thin'? You forgettin' 'bout Steve Barlow already?"

Caroline flushed angrily.

"What have you done to Steve?" she demanded. "Sometimes I think you've killed Steve and are still using him to keep me quiet. If I thought Steve was dead I'd go straight to the marshal an' tell him all about the hold-ups."

"I know you would," snapped Casson. "An' the mood he's in, he'd most likely believe you, too. But Steve ain't dead, an' you'll keep your mouth shut until I'm ready. If you don't, you'll never see Steve again."

"I think you've killed him already," said Caroline softly. "Unless you can prove to me that he's still alive, I'll go to the marshal."

"I think you would, too," snarled Casson. "Okay, I'll prove he's still alive."

"How?" asked Caroline anxiously.

"I'll take you to him," said Casson. "I'll let you talk to him, mebbe."

"When?" the girl demanded.

"Tomorrow, mebbe," replied the outlaw. "That's if you be good an' don't cause any more

trouble. But don't get any ideas. Don't do anythin' foolish, like tellin' the marshal an' havin' him follow us."

Casson left the room, for he had a lot to do. Already his boys would be on their way to High Water from their hide-out in the distant hills. Their raid on the town should be a great success this time, for it would occur when the marshal and maybe his posse of twenty or thirty men would be out scouring the canyon for Loner-gan. He hoped his boys would be on the alert and not come face-to-face with the marshal, for that could lead to disaster.

It had been three weeks now since the last raid on the town, and suddenly coming upon a band of a dozen riders heading toward High Water, the marshal would certainly guess that this was another raid.

OUT IN the street he was met by an anxious-faced Ty Garnsey. "Where in heck have you been?" Garnsey demanded of his leader. "I was beginnin' to think somethin' might've happened to you. The boys'll be here any minute now."

"I know it," snapped Casson. "Is everyone in position?"

"Yes," replied Garnsey. "We've got four men coverin' the street with rifles. We've jus' got time to get to the bank."

"Let's go then," said Casson, and they hurried off in the direction of the bank. "We'll make this one look good," said Casson. "Leave it to me."

"What're you gonna do?" asked Garnsey, fearing that his leader had some new idea which might bring them into added danger.

"I'm gonna play the hero today," said Casson, smiling. "When the boys get to the bank I'm gonna try an' pull a gun on 'em."

Garnsey looked at Casson in amazement.

"What in blazes for?" he demanded. "You tryin' to spoil things?"

"No!" replied Casson. "I'm jus' smart, that's all. It'll look good, but I'll be too slow. One o' the boys'll take a shot at me. He'll miss, o' course, but that'll be 'nough for anyone else in the bank. Nothin' like a shot at close quarters to discourage any fool ideas."

He looked at Garnsey, prob-

ably expecting to see admiration on his face, but Garnsey looked dubiously back at him.

"Guess it's all right," he said slowly. "So long as our man ain't a bit nervous an' shoots straighter than he should."

"He won't," said Casson confidently. "We arranged it all carefully yesterday. There won't be no slip-up."

They entered the bank, stood just inside the door as though discussing something, then approached the teller. Casson wanted to draw out a fair sum and was given a form to fill out. He took it back to a desk on the far side of the bank and took his time over it, on the alert for sounds of the afternoon stage-coach arriving.

"Here it comes," muttered Garnsey, as the sound of the galloping team reached them. "Let's get back to the teller."

The raid on the town had been well-planned. On the outskirts of High Water the twelve riders were to split up into smaller groups, so as not to attract attention as they entered the town from different directions. The arrival of the coach always brought most of the townsfolk flocking to the stage-

line office and it was while most of the population were interested in watching it that the bandits would act.

Casson handed the form to the teller and the teller went to a recess at the end of the counter and unlocked the safe door. As he got it opened the swing door of the bank was thrown violently open and four masked men entered, guns drawn.

There were a few other clients in the bank, as well as the manager and the two tellers. At sight of the masked men someone cried, "Hold-up!" But before panic could set in the four men had everyone covered and the leader of them was giving, crisp, cool orders.

Casson made a sudden movement toward the gun at his hip, but the leader turned on him and fired, the slug splintering the wall behind him. As Casson had expected, it was sufficient warning to the others and no one made any further show of resistance.

get the money, stuff it into a canvas bag, then retreat towards the door. From outside came the sound of gunfire as other parties of the outlaws went into action. Then came a shout from just outside the bank and the four men backed towards the door.

"First one to show his face outside gets it shot off," warned the leader of the bandits, and they turned and ran out of the building and jumped on their horses, joining the rest of the band as they thundered by.

It was a full minute before anyone in the bank moved, then there was a general surge towards the door. Slim Casson and Garnsey led the way and Casson threw a wild shot in the direction of the fast-disappearing riders. Men were by this time emerging cautiously from cover and they gathered in groups indignantly discussing the daring raid.

Casson and Garnsey moved among the groups, asking questions and finding out how the separate parties of raiders had fared. Three men had been killed in the raid, but none of the bandits had died, although it was rumored that one had

WITH THE safe door already open, it was an easy matter for one of the men to

been wounded, but had managed to stick on his horse.

Altogether, it seemed that the raid had been most successful, and the haul from the bank, the casino and the big general store must have been considerable. Casson and Garnsey moved away from the crowds at last.

"Looks like it went over big," said Garnsey. "The boys must've got a big wad o' dinero today, even bigger than last time, I reckon."

"I reckon we'll do all right out of it," agreed Casson, a satisfied smile on his face. "Weldon must've got careless, though. I'll have to speak to him 'bout that. I heard someone say they saw a fella up on the roof o' the stage-line office shoot a deputy. If that gets to the marshal, it might start him thinkin' things. Mebbe he'll wake up that these jobs are bein' worked from the inside as well. Part of our plan was to keep him thinkin' it was pulled off by some gang from outa town."

"It ain't likely he was recognized, anyway," said Garnsey. "He was smart 'nough to get down quick and mix in with

the crowd. I seen him talkin' with some fellas outside the saloon, so it sure don't look like anyone was suspicious 'bout him."

"No," replied Casson. "I guess it's all right. We're in the clear, too. Nobody could possibly connect us with the raid, anyway. So long as Weldon wasn't recognized we're quite safe. If he was recognized, though, he might talk. That'd be dangerous."

"Guess we'd better get him outa town then," said Garnsey. "Jus' in case."

"Guess so," agreed Casson. "Reckon we'll find him in the saloon. Let's go see."

THEY MADE their way to the saloon and, sure enough, Weldon was having a drink at the bar. The two outlaws strolled casually across and stood near enough to be heard by Weldon, but far enough away from him to disguise the fact that they were there for the special purpose of talking to him.

"Heard tell somebody recognized that critter on the roof o' the stage-line office," said Casson.

"That so?" asked Garnsey. "Things'll be mighty hot for him when word gets 'round. If he was smart, he'd beat it outa town pronto before the marshal gets back."

"Yeah," said Casson. "That's jus' what I was thinkin'. It was mighty foolish of him to let himself be seen."

Probably Weldon recognized the voices and was smart enough to give no sign that their conversation disturbed him. He finished his drink then strolled casually towards the door. Garnsey glanced after him, then smiled as he caught Casson's eye.

Although it seemed unlikely that anyone had recognized Weldon, Casson had given his man the impression that somebody knew of his part in the raid on the town. Casson had no doubt that the warning would be effective and that Weldon would get out of town immediately and make for the gang's hideout in the hills surrounding Dust Canyon.

As Casson ordered his drinks from the barkeep he heard a shout from the doorway of the saloon, and he turned in alarm as the words sank in. All eyes

in the saloon were on Weldon and the wild-eyed youngster standing in the doorway.

"That's the hombre I seen shoot the deputy!" the youngster had yelled.

There was little more than ten feet separating the youngster from Weldon and Weldon stopped in his tracks and shot a swift look around the saloon.

"He's one o' the gang!" cried the youngster and he clutched at his gun in a clumsy, inexperienced way.

Before his fingers had closed properly about the handle, however, Weldon had drawn and fired. Blood oozed from the lad's chest as he pitched forward without uttering a sound, and lay still.

Weldon looked belligerently at the others in the saloon as an angry cry of protest went up from all sides. Several men went for their guns and it was obvious to Weldon that if he were to escape he would have to make a run for it. He stepped over the fallen youngster and ran hard for the door, firing at random as he ran. A volley of fire from all sides of the saloon came in reply and a

slug caught him in the leg just as he reached the door.

The leg wound made him stumble, but he didn't fall. He was out through the door, and Casson realized he would be hard put to it to escape. As men rushed towards the door in pursuit Casson also started to run.

"Come on," he snapped to Garnsey.

CASSON could not get to the doorway until three or four men had already passed through, but he was in time to see that Weldon had been unable to mount his horse and was crouching behind a post, endeavoring to shoot it out. Not only his leg, but his shoulder now showed blood and Casson feared that Weldon might be taken alive. That was something which had to be prevented at all costs and Casson drew his gun and fired.

Weldon was already on his knees and a couple of men were rushing him in an attempt to capture the outlaw when the slug from Casson's gun caught him in the neck. With a strained, gurgling cry he dropped his gun, clutched at

his throat, then toppled backwards off the edge of the boardwalk and rolled to a stop in the dust of the road.

Garnsey looked at his leader, a startled expression on his lean face.

"So much for Weldon," he said, quietly, and there was something in his tone which Casson did not like.

"He can't talk now," muttered Casson, looking around quickly to make sure that nobody had overheard Garnsey's remark.

"No!" replied Garnsey, still looking rather stunned. "Jus' as well he can't. I'd hate to hear what he would say."

"You wanta swing?" hissed Casson. "I don't. If they'd killed him, all well an' good. But if they'd taken him alive there's no tellin' what he might've tol' 'em. We ain't had the success we've had by being sentimental. When there's danger you've gotta act quick."

"Wish you hadn't killed him, Casson," said one of the men who had been in the saloon. "I was hopin' we could've made him talk. Mebbe he'd have tol' us who he was workin' for. We might've been able to round

up the whole gang o' them owl-hoots."

"When a guy's throwin' lead like that he's gotta be stopped," snapped Casson. "He killed that youngster back there, an' he might've killed somebody else if I hadn't got him. The marshal don't seem to be able to do anythin' to stop these raids or maintain law an' order, so it's up to someone else to deal with these doggoned buzzards."

VII

TEX LONERGAN remained up in the tree until the last of the twelve riders had passed from view, then he descended, recovered his mount, and swung up into the saddle. He felt tempted to follow them, for he had little doubt that they were a gang of outlaws, and that they were probably setting out on some job.

In any case, it would give him something to do, for it looked as though he would have a lot of time on his hands while he waited for the hue and cry in High Water to subside. All

he had to do was to keep a wary eye open for the posse he knew would be looking for him. And in the range which gave him an excellent view of the canyon it should be comparatively easy.

He trailed the gang from a safe distance, down the hills until the twelve had reached the bottom and set out across the canyon. He hesitated to follow them any further, for he would have his hands full if they detected his presence and resented it. And if his hunch about them was correct, they would certainly resent it.

He halted his mount at the foot of the hills and watched the band of riders until they were hidden from his view by the thick, swirling dust of the canyon. He decided to await their return. He guessed that they were about to carry out some crime in High Water, the only town on those parts, and would in all probability return.

If they did return that way he would follow them again, for he fancied they must have a hideout somewhere on the range. Actually, there was the germ of an idea forming in his mind and while he waited he

had plenty of time to figure things out.

There must be some reason why Casson was the only person he had been able to find in High Water who knew anything about young Steve. And knowing Steve as he did, Tex was not really surprised to find that he had in some way become entangled with a man like Casson.

Steve was one who liked a good time, and his idea of a good time was to do anything he liked any time he liked. Work was one of the things he always tried to avoid, preferring to make his money by gambling or by way of some scatter-brained scheme.

As he thought of that, it occurred to Tex that Casson must have some dishonest way of getting his living, and it was just possible that young Steve had met up with Casson, and had fallen in with the outlaw. It was at this point that a thought suddenly struck him. Was it possible that the twelve riders he had just seen heading towards the town were Casson's men? And was Steve one of Casson's gang?

Tex had been able to get a good enough look at the twelve

to know that Steve was not among them, but it did not necessarily follow that Steve was not in the gang. Possibly he was in this very job that the gang had in hand, but had some other important part in the scheme.

The realization that Steve might be connected with the gang made him all the more anxious for the return of the outlaws and all the more determined to follow them to their hideout.

LONERGAN kept a look-out from time to time, straining his eyes to penetrate the dust-haze. When more than an hour had passed and there was still no sign of them he began to wonder if he had guessed wrong. Maybe he had let his enthusiasm run away with him.

He noticed that the wind had died down considerably now, and as a result visibility was much better. He reckoned that he could now see a mile or more across the canyon floor, which was a good thing because it would give him time to maneuver into position if the gang should strike the range at some point further north.

His keen eyes detected a dust cloud and he quickly recognized it as the type made by a group of horsemen. In a few minutes he was able to see them more plainly, but as yet they were not distinct enough for him to be sure of their number. They were not heading directly towards him, but he had plenty of time yet.

In a quarter of an hour he was sure of their number. There were twelve horsemen down there and they were beating it out at a solid pace. There was no doubt in his mind now, and he nudged his mount into a walk, heading north along the foothills of the range. A walk was good enough, and it gave him the chance of keeping his eyes on the outlaws and trying to judge the point at which they would take to the range.

He saw that the riders had now allowed their mounts to slacken pace a little, apparently confident that they were not being pursued, and when he had reached a point at which the outlaws were heading straight for him he halted his mount again.

It would not be long before the men reached him, and he

looked about for some suitable cover for himself and the horse. It would have to be cover that would hide him while still mounted and yet be close enough to the course they would take to enable him to follow them as closely behind as safety would allow. The excitement was beginning to get him, but he was thinking coldly and clearly.

Higher up the range the ground became more and more rugged. It was more thickly timbered, and there were plenty of loose boulders and rocky outcrops. If he let his quarry get too far ahead they might prove very difficult to pick up again. After a last look down the canyon he settled for a clump of trees which he hoped were thick enough to hide him from the view of the men as they passed.

There he waited for ten minutes or more, but at last he heard the clump of horses crashing their way through the trees and tall grass, and the sound of rowdy chatter. He heard the sounds approaching, then after a time begin to grow fainter and less distinct, and he realized that the riders had not

come as close as he had expected.

He came out from behind cover, allowing his mount to pick its own way and make its own pace over the now dangerous terrain. From time to time he caught a loud laugh or a shout, and it happened often enough for him to be sure he had not lost track of his quarry.

Occasionally, there would be a break in the trees which would allow him to catch a glimpse of the men, and since all thoughts of pursuit had left them there was little danger of Tex being discovered. He found that the band were climbing now and the going became very tough.

IN HALF an hour the party had reached the top of the range, and as yet had given no indication that they were anywhere near their hideout. As Lonergan in turn topped the peak of the range he saw that the ground on the far side was not as rough, and the trees thinned out considerably. He would have to be more careful now, but it worked both ways, for the possibility of los-

ing sight of the outlaws was slim.

Finally he reached a point where it would have been sheer folly to proceed any further. There were only a few isolated trees and the ground fell away in a steady, smooth slope. He watched while the outlaw band went forward in single file through a shoulder-high gap in a rocky ledge, beyond which the ground appeared to fall steeply.

He waited until the last had disappeared from his view, then walked the horse down to the spot and dismounted. He crept forward cautiously, not knowing what was beyond, and realizing the possibility that the men had not gone much further. He peered over the edge of the rock, then drew back quickly as he saw that the men had all dismounted beside a cluster of half a dozen small log-cabins.

Tex had no doubt that this was the owlhoot hideout, but having found it, he was at a loss to know what to do. With a dozen men in the camp, maybe more inside the cabins, it was too risky to go any closer. He was about to withdraw, con-

fidant that he could find the hideout again if necessary, when a dark-haired young man appeared for a moment in the doorway of one of the cabins. It was Steve Barlow, and a frown crossed Tex's face with the realization that young Steve was indeed tangled up with this group of outlaws, probably Slim Casson's men.

He had found Steve at last, but what was the use? If the youngster had taken to a life of lawlessness there was not much likelihood of Tex being able to influence him to give it up and come back home. He would try to get to talk to Steve, of course, but it would have to be when he could get the youngster alone.

He was about to try to work his way down closer to Steve's cabin in the hope of slipping inside when the opportunity was there, when he stopped again. Steve had now stepped right out in the open and was talking to three of the other men. He could not hear what was being said, but they appeared to be arguing.

The man to whom Steve seemed to be mainly directing some protest was the man

whom Tex had judged to be the leader of the twelve riders. He was a big man, very broad in the shoulders and exceptionally tall, not far off six and a half feet, Tex thought.

After a further exchange, which seemed to be getting more heated with every word, Steve rushed at the big man and lunged out with his fist. It caught the outlaw hard in the chest and with a yell of rage the tall man hit back. His blow caught Steve in the face and the youngster went down.

He scrambled to his feet again and tried to hit out, but the other two men caught him, one of them holding his arms firmly behind his back while the other planted a fist flush to the lad's jaw. Steve crumpled up in the outlaw's arms and was dragged back again inside the cabin.

Tex's face set grimly as he watched, and it was all he could do to refrain from rushing down to the youngster's assistance. It was one thing to tackle odds, but it would have been just plain silly to pit himself against a dozen or more men in an attempt to help Steve then.

What he had just witnessed altered his ideas somewhat. It appeared that maybe Steve was not at the owlhoot hideout from choice, but was being held there against his will. Just why that should be, he couldn't even guess, but he meant to do something about it.

He moved cautiously back to where he had left the horse and climbed into the saddle. Already there was a plan forming in his mind. It was risky, but there was a chance that it might work. He intended to ride back to High Water and find out if the gang had pulled off a job in the town. If so, he would see the marshal and try to get him to bring a posse out to the range to raid the outlaws' retreat.

VIII

BY THE time Tex Loneragan had made his way back over the top of the range and was descending once again to the canyon floor the sun had already slid down behind the western rim. It would not be long before complete darkness cloaked the canyon, but if anything, that would be

a blessing. In daylight it was a hard ride for the toughest of men and horses, but at night, without the choking dust it was quite different.

The only hazard was in trying to find one's way accurately without a landmark of any description. Men had been known to wander all over the canyon through the night, only to find that in the morning they were as far as ever from High Water.

But Tex was confident that he could head his mount in the right direction and keep it on the target. He had the stars to guide him, and a man who had wandered the west as Loneragan had could make good use of the stars. As he rode, he planned. Planned as far as he could, anyway, for he knew that once he reached the town anything could happen.

As soon as he was spotted in High Water, the alarm would be given, and he would have to move quickly and with great caution to get to the marshal before the mob could take the law into their own hands. Even then, his troubles would not be at an end, for he still had to convince the lawman that he

could lead him to the owlhoot hideout. And that in turn, was assuming that his hunch had been correct, and that the outlaws had been on some lawless excursion in the town.

It was late when he caught his first glimpse of the little cluster of flickering lights of High Water. That was good, because it would mean that there would be few people on the streets to notice his arrival.

He rode into town along the main street and past the marshal's office. The place was in darkness, as was to be expected at that hour. Probably the lawman could be found in the saloon, but Tex had no intention of risking an appearance there. There were too many people to allow him to talk to the marshal unmolested.

HE HAD no friends in the town, with the exception of Duff Colton, the barkeep, but he would also be in the saloon. Then he thought of Caroline Casson. She had helped him once. Maybe she would again. But where to find the girl was a problem. He looked up at the darkened buildings, and at the windows,

all so much alike as to make it almost impossible to be sure which was the girl's room.

There was only one way to find out, however, and he stood up on the saddle and pulled himself up on top of the awnings. All he knew was that he had the right group of buildings, and that one of those windows belonged to Caroline's room. Most of the rooms were in darkness, but lights showed in three, so all he could do was to investigate those three.

The first window revealed a poker game in progress, and all he saw in the next room was a man sprawled across a table which was littered with bottles and a glass. At the third window, however, he gave a grunt of satisfaction. It was empty, but he immediately recognized the spread on the bed under which Caroline had hidden him earlier in the day.

He guessed she could not be far away, otherwise she would not have left the lantern burning on the dressing-table. He opened the window and climbed through. In a few minutes he heard the sound of someone coming along the passage outside. They were quick, light

steps, and he stood up as Caroline flung open the door and came in. She uttered an exclamation of surprise at finding somebody else in her room, but was relieved when she recognized Tex.

"Well!" she exclaimed. "What are you doing here?"

Lonergan noted that her tone was friendly.

"Sorry to come into your room like this, uninvited," drawled Tex. "But I'm in need of a friend. Apart from you, I've only got one other friend in this town an' he's got too many other folks 'round him jus' now."

"You're taking a risk coming back to High Water," said Caroline, a trace of anxiety in her voice. "There's a price on your head, you know. The raid today hasn't improved things either. If they can't get their hands on that outlaw gang they'll make do with you."

"What raid?" asked Tex quickly.

Caroline gave him a brief outline of the afternoon's happenings and it made good listening to Tex. He knew now that his hunch had been right.

There was just one more thing he wanted to know.

He said, "Caroline, I think your brother's mixed up in that raid, don't you?"

The girl looked at him sharply, then looked away as though trying to come to a decision. Then, her mind apparently made up, she looked at Tex again, her face serious.

"I know he is," she admitted.

"Then if you hate him the way you seem to, why don't you tell the marshal what you know?" asked Tex. "I know he's your brother, an' that, but..."

"He's not like a brother to me," snapped Caroline, real venom in her voice. "I hope he gets caught, but I can't tell the marshal."

"Why not?" asked Tex, puzzled.

"There's a good reason," replied Caroline. "He's holding someone prisoner somewhere. If I tell the marshal about him, he'll kill my friend."

"So that's it?" said Tex thoughtfully.

"Yes," replied the girl. "For all I know he might have killed my friend already."

"No, he hasn't," drawled

Tex, a faint smile on his face. "Young Steve's very much alive."

"Steve!"

THE GIRL'S eyes opened wide in amazement.

"You know Steve?" she asked excitedly. "You've seen him? He's well?"

"Yeah," said Tex. "He's a friend o' mine, too. That's why I've come to High Water—to find him. Now I've found him, but I'll have to bust open a camp of anythin' between fifteen an' twenty men to get him out. That's why I come back. I've gotta talk to the marshal an' get him to send out a posse. I'll lead 'em to the hideout."

"But will the marshal listen to you?" asked Caroline in alarm. "The minute he sees you, he'll arrest you. Then he'll think you're just telling him a tale to try to escape."

"Not if you back me up," said Tex. "He'll believe you."

"But you can't go until the morning," protested Caroline. "And I'll be gone."

"Gone?" asked Tex.

"My brother's taking me to see Steve," explained Caroline.

"He's going to prove Steve's still alive, so I'll continue to keep quiet about his crooked activities. If I don't go, he'll get suspicious. We're leaving at daybreak."

Tex rubbed his chin thoughtfully.

"In that case, you'd better go," he said at last. "One thing we don't want is for your brother to know he's through. I'll bring the posse somehow."

Caroline knew of an empty room along the passage, and Tex took the opportunity of snatching a few hours of sleep. Then he was awake again, and watched from his window as Caroline and Slim Casson rode out of town in the direction of the canyon.

He waited until, from his window, he saw the marshal arrive at his office to begin work, then made his way down into the street. He passed nobody on his way to the lawman's office, and he threw open the door and strode in.

TO LONERGAN'S amazement the marshal was facing the door, his gun trained on Tex. "Seen you through the window, Lonergan," he said.

"You're gettin' kinda careless, ain't you?"

One glance at the lawman's face showed Tex that he would have little chance of convincing him of the truth of his story. A wild scheme formed in his mind instantly, and before the marshal knew what had happened Tex had overturned the table between them and sent it crashing back on the lawman.

Tex was out of the door before the marshal could fire, and ran across the road to where he had tethered his mount the night before. He was into the saddle and galloping up the street by the time the lawman emerged from his office and sent a shot after him.

Tex looked back as he rode out of High Water and grinned as he saw men running in all directions as the marshal gave the alarm. In a matter of minutes he would have a posse after him and he meant to lead them to the outlaw hideout.

Tex kept the big colt moving at a fast pace across the canyon and looked back from time to time to make sure he was not getting too far ahead of his pursuers. By the time he had reached the foothills they had

him well and truly in sight and as he climbed he made sure of showing himself at intervals.

The game colt never faltered over the rugged terrain of the range, and Tex eased up as he reached the peak to enable the posse to get closer.

All hell broke loose as the posse suddenly found themselves being attacked by a score of men, but they gave battle, though probably only a few of them realized that they were fighting the owlhoots who had twice raided High Water.

Tex used his guns to good effect and brought down two of the outlaws, but his main objective was the cabin in which he had seen Steve the previous day. He ran in through the open door and stopped as he saw Steve with Caroline in his arms. There was no one else in the cabin.

"Where's Casson?" asked Tex after a brief word of greeting to Steve.

"Beat it up over the top, headin' for the canyon," said Steve. "I'm goin' after him."

"No you ain't," said Tex. "He's mine! We've got some-thin' to settle."

AS HE DASHED out of the cabin and remounted he saw that the battle was petering out and that the last handful of the outlaws had surrendered. He headed the big colt up the range and heard the marshal shouting.

"Come back, Lonergan! I don't want you any more!"

Tex turned in the saddle and waved a cheery farewell to the lawman, but rode on.

Tex sent the big colt down the range on the canyon side. He was anxious to catch Casson before he reached the canyon floor, for already a high wind was blowing and before long the red dust would rise to aid the outlaw's escape.

He soon caught a glimpse of Casson. The outlaw leader was close to panic as he looked back and saw Tex close behind him. His mount took a wrong turning and reared wildly as it broke through the trees to find itself suddenly on the edge of a hundred foot drop. Casson was thrown from the saddle, and the unfortunate animal came down, then slithered over the edge.

Casson was cornered, but Tex was on him before he had time to shoot. He had been quick to act when he saw the outlaw's plight, and he slipped from the saddle and came at Casson on foot. The two men closed in combat and both knew that only one would survive the fight.

Tex's onslaught came before Casson was prepared for it and he was unable to recover. A hard blow in the stomach doubled him up in pain and Tex followed up with a right to the jaw. Casson was lifted clean off his feet and staggered back. His feet slipped on the smooth edge of the ledge. The outlaw screamed as he clutched at the edge with his fingers and missed. Then he vanished from sight.

Tex stood looking down a while. His face was pale, but as he walked back to remount, the color returned and he smiled faintly.

"Now it's me for Green Hills," he said aloud. "Looks like Steve won't be comin' along, but I guess I can manage that ranch if I have to."

FEET OF CLAY

by John Harrison McLean

Unlike John Wesley Hardin, who seemed to be followed around by trouble, Clay Allison went looking for gun-fights — and usually found them. He enjoyed killing — particularly when his opponent was a lawman...

THE FACT that a man was a killer in the days of the Old West didn't make him good or bad. There were men who hid behind the protection of a badge and didn't give a hoot what they did. The sad story of Henry Plummer reminds one that even in those days, crime was big business. They say that Plummer and his gang killed more than one hundred and twenty citizens who happened to be slow on the draw; plundered stages, express

shipments, and private citizens. He appointed road agents as his deputies. So when a coach was held up, the boys went out looking—for themselves. The vigilantes eventually caught up with Plummer. But in the case of Clay Allison—well, Clay just drank too much and died while trying to break a team of mules to the harness.

Clay was born in Tennessee in 1835 or thereabouts, and as a young man he moved to Texas to enter the cattle business.

Clay liked to outshoot badge-packers . . .

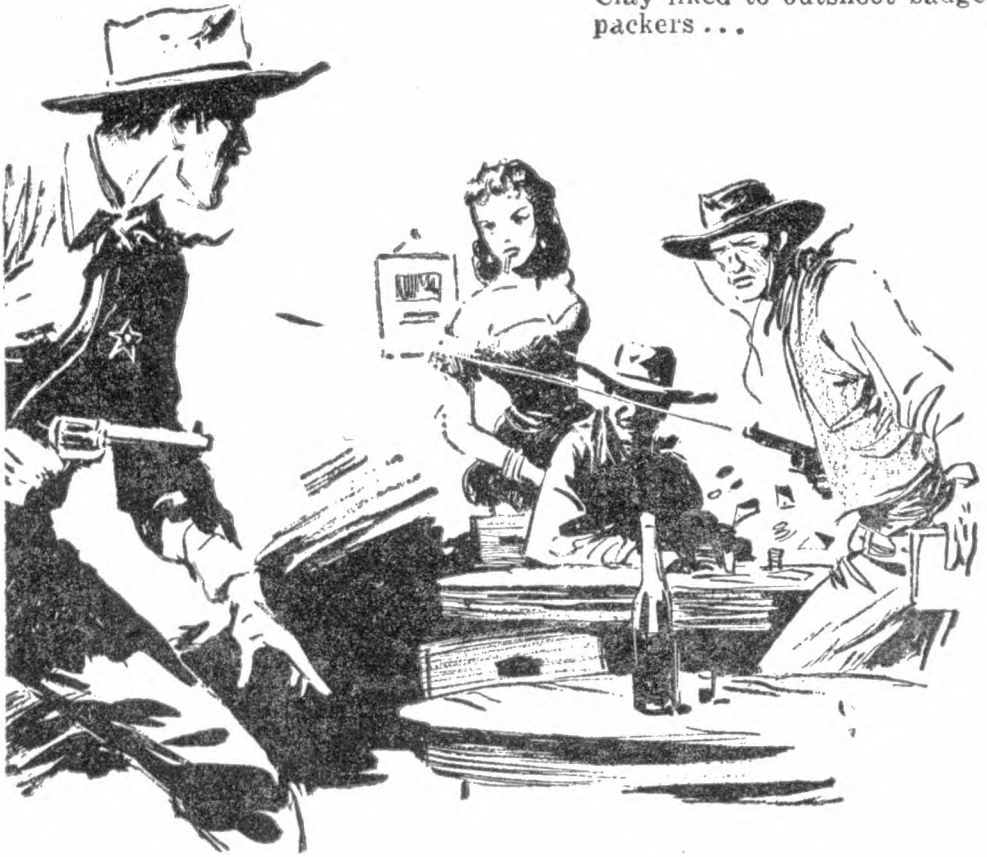

Either he adopted Texas or Texas adopted him. Which happened isn't too much of importance, but what does count is the label: *Texan*. Or its equivalent: *Tough*. Texans liked to boast that they were equal to any emergency that could arise when it required brawn. There was a little poem way back that went this way:

*Raised in a canebrake,
Fed in a hog trough,*

*Suckled by a she bear,
The click of a six-shooter is
music to my ear.
I'm wild and woolly and full
of fleas;
I've never been curried be-
low the knees.
I'm a wolf with a barned-
wire tail;
I'm a wolf and it's my night
to howl.*

There was a pride in being tough. Sure, you had to be

tough in those days to live; but you also had to have enough sense in your skull to know how to avoid a fight without losing face. If Wyatt Earp went after every drunken cowboy who wanted to fight, they would have buried Wyatt with his boots on, very early in his career.

The Civil War—or the War Between the States—wasn't exactly a very pleasant affair. It had a lot of men in it and almost burned up the country. But let's get one thing straight. The text books like to tell the kids it was the first fight here in which brother was against brother. That just isn't so. In the Revolutionary war, we had Tories fighting the "Rebels." It was colonists versus colonists and some of the things that happened were rather sickening.

CLAY'S SYMPATHIES were with the Confederate States of America and he served well as a spy. He got caught by the Federals and they were ready to give him the standard dose for all spies: Death by a firing squad. If you want melodrama, Clay supplied it because he escaped the night before they

were going to stand him up against a wall. It was once fashionable to call him a Yankee-hater. But let's just remember, first you got to hate and then it's easy to find a tag to justify the hating.

A lot of other good sound Western men fought in that war. William F. Cody served on the Federal side, and it is hard when reading Cody's autobiography to separate imagination and fiction from reality. We do know that there is an official record of his enlistment with the Seventh Kansas Regiment, known as Jennison's Jay-Hawkers. And Cody does tell us all about his exciting experiences as a scout for General Smith. In poverty or success, whether sober or drunk, Cody never had any hatred inside of himself. But Clay Allison had a lot of hatred in his guts.

Wild Bill Hickok was also a spy and scout in the war, on the side of the Federals. He worked under General Curtis, and was sent to get some important information. He assumed the name of Bill Barnes and enlisted in a regiment of mounted rangers that was attached to the command of General Price. He

had a lot of adventures. I would have liked to stage a pistol duel between Hickok and Allison. Want to bet on the results?

HERE'S ONE of the stories about Clay Allison with the comment that you can take it or leave it. It concerns the so-called "Grave Fight"—enough to give even a strong man a chill down the spine. Clay was doing well in the cattle business in Texas, and it looked as though he was going to be one of the big cattle kings. Then he got into an argument with a friend and neighbor. No way of settling the feud. So Clay, with the touch of that grim sadistic humor that always hung around him made a suggestion.

"Let's go out on the plains. We dig a grave. Make it six feet deep, six and a half feet long, and two feet wide. We then strip ourselves to the waist. You sit at one end of the grave and I'll sit at the other end. Only weapons we use are Bowie knives. When the signal is given, then we start fighting.

And we keep on fighting until one of us is dead. The survivor agrees to bury the dead man.

Just push in the earth on the side."

According to the story, Clay and his friend fought a rather bloody duel. Clay killed his man and buried him according to the agreement. But he himself had been so badly wounded by a knife thrust in the leg that he was thereafter lame. So lameness became a mark of distinction for him, as it did for Bat Masterson. But shades of Jim Bowie! This reminds one of the fight between Jim Bowie and gambler John Sturdivant, where they fought with their wrist strapped together. Only the end is different. Bowie made a sudden lunge and Sturdivant's knife falls to the floor. Then he cuts the buckskin bond and says, "I'm not killing you. I wouldn't kill a defenseless man. I reckon, though, that I've cured you of knifing men for a while at least."

But Clay Allison would kill anybody.

AFTER THAT duel, Clay sold his cattle interests and then moved to Colfax County in New Mexico. He did well and they say he was a likeable man when sober. He was tall,

about six feet two. Picture him with black hair, mustache and blue eyes. He also liked to dress in fancy clothing. It made him stand out—just as fancy dress did for Bat Masterson. But when Allison got the liquor under his belt, he looked for trouble and found it.

He could handle that six-shooter of his with deadly accuracy, and soon helped to fill the local graveyard. They claim he killed so many men that he never stood or sat in a room with his back to a door or a window. He had enough sense left to realize that the friends and relatives of the deceased one had a score to even up. It generally makes a man jumpy when he has to be alert every minute of his time so he doesn't get a bullet or knife to finish him off. We mentioned Wild Bill Hickok, so let's go back to him for a minute or so.

During the period that Wild Bill was scouting for General Curtis, he also fought one of those crazy duels to the death. It was with an Indian Chief. It seems that the chief of the Sioux, Man-to-yu-kee (Conquering Bear) appeared before General Curtis at Leavenworth

and offered to accompany any white man he might choose to send as a spy into the enemy's camp. Wild Bill went and had his suspicions aroused; he told the Indian that if he betrayed him death would be the consequence.

Hickok was led into a trap and escaped, but he wanted to even things up with Conquering Bear. A friendly Indian helped out, and lured the chief to a spot where he faced Wild Bill. Bill then told the chief he intended to kill him for his treachery. He threw the Indian a pistol telling him to defend himself. The chief knew Bill to be a dead shot and objected to fighting a duel with pistols. However he agreed to fight with knives.

AND SINCE Hickok carried a Bowie knife, the fight was soon on—but not until a circle had been drawn as the "ring". Both were soon bloody and hurt. The end came when Bill's knife cut the Indian's throat, almost severing the head from the body. It was several months before Bill recovered the use of his arm.

On August 2, 1876, Wild Bill

was playing a game of poker in Deadwood. And he did something unusual—he sat with his back to an open door. And through it came Jack McCall. Call him a bum with an inferiority complex, who figured he would be somebody Big if he killed a well-known fighter. (Or maybe he really was only avenging his brother, whom Hickok had killed years before). One shot and it was over; Wild Bill Hickok slumped, letting his hand fall to the table—with aces and eights in it!

Sure, Wild Bill was a killer. And so was Clay Allison. But there was one big difference, and it didn't have anything to do with the fact that Wild Bill was at times an efficient lawman. With Hickok, the killings had sense; with Allison, they were senseless.

THEY SAY that Clay Allison just got rid of the Mexican ranchers near Cimarron, New Mexico, when he wanted their land for his own ranch. Anyway they vanished and he was there and his herds soon increased. But his fight with Pancho shows how careful a fellow had to be when there

were others gunning for him.

I'll take the version of the Pancho fight that makes this fellow a tough desperado. The scene was in one of the saloons in Cimarron. The day was warm. Pancho looked all smiles.

"Have a drink with me, my friend," suggested the man.

So there they were at the bar. Clay Allison had no quarrel with the man; there were enough of those with whom he had quarreled to keep him always on the alert. But if Pancho killed Clay—it would increase his stock.

"I feel warm," smiled Pancho as he took off his wide-brimmed hat and began to fan himself. It was a form of the old "distracting stunt." But Clay's keen eyes watched the other hand as it slowly descended to the vicinity of the holster. And as the fingers fouched the gun, Clay went into lightning action. He pulled out his six-shooter and one shot took Pancho from the land of the living to the other side.

"You all saw what happened," Clay said, right after the shooting. "It was self-defense. I'm going before the Justice of Peace."

Which he did and the verdict was that he killed in self-defense; and in this situation he was really justified. But that really wasn't necessary; Clay Allison was the law in Cimarron. For a time it was hard to get a man to fill the shoes of town marshal. For when Clay had too much to drink, and there was the possibility he wouldn't be such a fine expert with his gun, his equally rotten brothers were on hand to be certain that Clay walked away alive.

CLAY ALLISON enjoyed horse racing and he at times seemed to like horse flesh better than human flesh. It was at one of these horse racings that he decided he didn't like another desperado called Chunk. The feeling was mutual.

"Any time you want to fight, it's all right with me," challenged Chunk.

"Fine with me," agreed Clay Allison. "We could go out and face each other with pistol in the hand, but I have a better idea. You mount your horse and I'll mount mine. When the signal is given we ride towards

each other with our guns in our hands. Fire at will. And keep on shooting until one or both of us have hit the ground."

"Suits me," asserted Chunk. "Let's do it right now."

Maybe Clay had never heard about the famous duel Kit Carson had on horseback. It could have just been an original flash in his own brain. But he had something else to add.

"It's a helluva way to go to hell on an empty belly. So let's go in and eat a good meal.

Some say that Chunk made the suggestion. So hand in hand the two went into a dining room. They saw a long table with people on both sides, two empty chairs at each end.

"You sit at one end and I'll sit at the other," grinned Clay.

SO THE TWO sat down. Clay took his pistol from his holster and placed it right next to his soup plate. Chunk took his gun and dropped it in his lap. The guests on either side of that table were getting a bit nervous.

The first course was naturally—soup. Clay lifted the spoon to his mouth. This seemed to be the perfect time

for Chunk to do his killing; he shifted his hand and went for his gun. But Clay saw the movement and dodged to one side. The spoon hit the floor after Clay's gun went into action. Chunk's bullet went wild. but Clay's bullet made a bull's eye in the forehead of Chunk and he slumped over the table—dead.

Back went Clay's gun into his holster. He looked at the frightened people at the table. And then calmly announced. "Hope you don't mind if I finish my meal."

They were too scared to leave the table and the meal went on as though nothing happened. Except that they all—with the exception of Allison—had indigestion because of the corpse at the table. And Clay announced that the duel was off!

Clay Allison was definitely an exhibitionist. Too bad that some of these modern day Psychiatrists and Psychologists have passed up a fellow like him. For Clay got a kick out of being in the *nude*! Once he stripped to the waist and rode around town shooting off his gun; but doing Lady Godiva

really should belong to the female sex.

THERE WAS once a dance hall gal who had a little too much to drink. I think her name was Rose. but I wouldn't place bets on it. She made a wager she would parade through town in the nude. But with a warning: She'd shoot out the eyes of any cowboy who peeped at her. And there she was—stripped clean except for the six-gun in her hand. She won, and they say nobody tried to peep.

But Clay decided to do it without the horse. And it actually happened in Las Animas, Colorado in the Spring of 1876. Clay and brother John were making the rounds that particular night. At one dance hall the two decided to get rid of their clothing. So right on the floor—while the folks were dancing—Clay and John unloaded everything but their six shooters.

"Just keep on dancing." yelled Clay as he waved his gun around.

The music went on and the men and women moved their legs as though they were danc-

ing—with Death the uninvited companion. Somebody ran to Sheriff John Spear and told him what happened.

“Round up a posse,” the sheriff told his chief deputy, Charlie Faber. “We have to stop that madman.”

So Spear, Faber and about fifteen other brave men soon got together and headed for the dance hall. Charlie Faber was the first one who showed up in front of the door. He figured that when you went for a madman with a gun—and you were the law—you shot first. Which he did; he wounded John Allison and that moron sank to the floor.

CLAY PUT his six-gun into action and the first bullet killed the chief deputy. Then he dragged the body to his wounded brother and remarked. “John, this is the damn son-of-a-bitch who shot you. But I got him all right. Don’t worry. You’ll be well.”

It must have really been a crazy scene, for they say that Clay cried as he tried to help his wounded brother. And at the same time get dressed and keep people at bay with his

gun. The Sheriff and the posse beat a strategic retreat when they saw the deputy dead. What happened to Clay?

He was again acquitted—it was self-defence—for the deputy sheriff had opened fire without warning of any kind. No wonder with such a decision that Clay Allison felt the contempt he showed for the law. You find in the records a sickening repetition of his sadism. He had to kill—he had to injure.

He went on a drinking spree with Bucksin Charlie. And of course the two quarreled and then followed the challenge to a duel.

“No guns or knives. just our bare fists.” suggested Clay.

Once Clay got Charlie down, he just beat him to a pulp and they took what was left to the hospital to try to patch up.

He would take a shotgun and shoot at a stove-pipe that he didn’t like. The people called all this “Clay Allison’s foolishness and fun.”

Then there was the day he walked into Harrington’s New State Saloon. He began to shoot right up into the ceiling. Never mind that a card party was go-

ing on in full swing upstairs. But the cards and chips got jumbled up on the table as the players all made a dive for some safe spot. This is western humor? He was just on a drunken spree that lasted for more than a week. But his horse was smarter than he was. Clay wanted to get his horse drunk. So he would bring out a bucket full of beer for the thirsty animal to drink. Just one swallow and the smart animal would upset the bucket. He wanted only water and nothing more. Too bad that Clay couldn't settle for that aqua pura.

DID HE MEET his match? It seems part of the legend and lore, that sooner or later every western gunman was to come up against the better man. Who would make him eat crow or crawl into his corner or back down in public. John Hardin says he did it to Wild Bill Hickok. In his own version it goes this way:

"I spent most of my time in Abilene in the saloons and gambling houses playing poker, faro, and seven-up. I was rolling ten pins and my best horse

was hitched outside in front of the saloon. I had two six-shooters on and I knew the saloon people would raise a row if I did not pull them off. Several Texans were there rolling ten pins and drinking. I suppose we were pretty noisy.

"Wild Bill came in said we were making too much noise. And told me to pull off my pistols until I got ready to get out of town. I told him I was ready to go now but did not propose to put up my pistols, go or no go. He went out and I followed him. I started up the street when some one behind me shouted:

"Set up. All down but nine."

"Wild Bill whirled around and met me. He said: 'What are you howling about and what are you doing with those pistols on?'"

"I said: 'I am just taking in the town.'

"He pulled his pistol and said: 'Take those pistols off. I arrest you.'

"I said all right and pulled them out of the scabbard, but while he was reaching for them, I reversed them and whirled them over on him with the muzzles in his face, springing back

at the same time. I told him to put his pistol up, which he did. I cursed him for a long-haired scoundrel that would shoot a boy with his back to him (as I had been told he intended to do to me). He said, 'Little Arkansasaw, you have been wrongly informed.'

"By this time a big crowd had gathered with pistols and arms. They kept urging me to kill him. Down the street a squad of policemen were coming, but Wild Bill motioned them to go back and at the same time asked me not to let the mob shoot him.

"I shouted: 'This is my fight and I'll kill the first man that fires a gun.'"

IF YOU BELIEVE this story, then Wild Bill Hickok ate crow. But just remember: This was written years later by Hardin in his room where he was drinking the hard stuff almost by the gallon. And I can't find any outside source to substantiate this claim. However, it was Hardin himself who ate crow and backed down. Jeff Milton made Hardin eat his own words down in El Paso.

It was a very simple chal-

lenge. Jeff faced Hardin and said: "I understand you told Captain Carr that you hired me to kill M'Rose so you could get his woman. I told them you're a goddamned liar and I've come to get you to tell them the same."

Fighting words in any man's language or territory. More words followed and then the terrible insult. Hardin admitted he had been drinking. But Jeff Milton wasn't satisfied.

"That don't go. Tell them you were a goddamned liar when you said you hired me to kill M'Rose."

And fearing he couldn't beat Jeff to the draw he said, "I was a goddamned liar."

Hardin's finish came in the Acme Saloon. John Selman got in behind the swinging doors and fired with Hardin's back to him. His last words before death closed in were gambling words: "Four sixes to beat." Then he left this world. But Jeff was always a true man. When Selman wanted to shake hands with him, he snorted back: "I don't mix with a murderer. You shot that feller right in the back of the

head. You can't shake hands with me, certain!"

THEY SAY that even the fearless Ben Thompson once backed down from a showdown and it was with his pal, King Fisher. Both had been drinking heavy that day. Then they boarded a train for San Antonio. Ben got into an argument with the porter, pulled out his six-shooter and the poor porter shivered in his shoes. King Fisher tried to qualm Ben down. Then words passed between the two men.

"I told you to sit down and behave yourself," King Fisher insisted. "And I mean it."

"If I don't—what then?" demanded Ben.

"Guess I'll have to kill you," was the reply.

I'm not so sure this was a backdown in the real sense of the term. One or both would have been killed—and they had more drinking to do. And soon the two would meet death in the Variety Vaudeville Theatre in San Antonio.

YET, THE man who made Clay Allison crawl wasn't the killer type himself. His

name was Mason Bowman. His quarrel was that Clay had killed his nephew. So he saddled up his horse and rode right to the Allison ranch. That alone took a heap of nerve.

Clay faced Mason and lied. Said it was a case of self-defence and that the young man had boasted he would get Clay. That satisfied Bowman, but Clay had another problem on his hands. When Bowman learned the simple truth—that his nephew had been shot down in cold blood for the same reason others had been killed—Clay just didn't like the way that looked. There would be a killing. So Clay figured to get Bowman into a situation and wipe him out.

"Let's ride back to Cimarron," he suggested.

Bowman agreed and the two made for the nearest saloon. The drinking began. Clay watched for the right opportunity to go for his gun; but when he made a move so did Bowman. And what was maddening was the fact that Bowman held his liquor well and was a bit quicker and more alert than Clay. Bowman knew what the score was. In fact,

when Bowman later went to Tascosa his fame preceded him. They elected him sheriff of Colfax County. A tribute to the man who had "bested" Clay Allison.

BUT THIS rankled Clay. The more he thought about it, the more he was determined to even scores: Shoot up Tascosa and wipe out Bowman. That would show them all that Clay was still the terrible tough man. He got his two brothers and half a dozen cowboys from his ranch and rode over to Tascosa. Bowman was ready, with his six-shooters on his hips and a shotgun in his hands. He faced Clay and gave him a warning.

"Just turn around and ride out of town nice and peacefully."

One against eight? Clay knew the range of the shotgun. Too close to it now. So he turned and there were witness to watch him go the other way. Out of range, Clay fired his revolver into the air. It might be a signal for a mass attack. Bowman just placed his shotgun against the wall of the building, took up his Sharps

and fired once. The bullet ripped a hole in Clay's chest and it took him some time to recover.

SOMEHOW, at this point I always think of the poor dentist who got the raw deal at Clay's hands. He should have had a shotgun to blast Clay into eternity. There are various versions of that episode. It happened in Pueblo that Clay began to get pain in his jaw from one of his teeth. It was infected and had to come out. His brother was with him so they paid the dentist a "friendly" visit. Clay pointed to the offending molar and gave an order. "Pull it out!"

Without the use of too much imagination you can see the trembling dentist trying his best—especially when one patient is holding his six-gun, and another man is in the office also ready with firearms. The tooth came out and Clay paid his bill. Then he and his brother went out to do some more drinking.

In the next saloon, Clay made a simple discovery. "He took out the wrong tooth!"

So back went Clay and his

brother to even matters up. A screaming dentist was soon smashed on the head and laid out on the floor. Then Clay went to work on his and overdid the "eye for an eye." He yanked out all the dentists' teeth in his crude way and left the bleeding man on the floor. You got any comment on this one?

WHAT CLAY tried to do to Dodge or Dodge did to Clay is a matter of controversy. To many a cowboy, Dodge City was a sort of a mecca. To young George Bold it was a bitter disappointment. As he dryly remarked it looked dirty, makeshift. Near the depot, towering piles of sun-bleached bones were as high as the top of the freight cars. The dreary collection of clapboard houses, low and flat under a gray and cheerless sky and the grisly pile of bones gave the youth an overpowering feeling of loneliness. He almost wanted to leave "famed" Dodge City.

But there was kindness in that city. A "stranger" helped the youth to the hotel; asked some questions; and was ever around later to see that George

Bold didn't make too many mistakes. The "stranger" was Bat Masterson—kind when kindness was needed—and hard and firm when the situation demanded it.

THEY DIDN'T shoot blanks from their six-guns when the cowboys felt like celebrating. You have those who felt that Clay Allison stood for the right of the Texan cowboy to be himself, and that he was ready to challenge the law in Dodge to enforce that right. But one thing was certain. This time Clay Allison would come up against men who could handle themselves; their guns; and also had friends. It looks as though Doc Holliday was out of town when Clay decided to have a showdown. Which was probably lucky for Clay for that special short-barreled shotgun of Doc's would have made mince meat out of Clay.

But with Wyatt Earp, Bassett, Luke Short, and others, you had a group of men who could plan ahead and use some sense and strategy in handling a situation. Actually Clay didn't need an excuse to begin his private "war". It was fur-

nished in the corpse of one George Hoyt. Eddie Foy was in the Comique Variety Hall and Hoyt blazed away with his six gun. He almost got Wyatt Earp. Later, Wyatt and Bat chased Hoyt and there was more shooting. Net result: A wounded man who later died.

THE FACT that the late Hoyt was also an outlaw with a price on his head probably only endeared him more to Clay. He primed himself up with a lot of liquor and was ready to shoot it out—provided he remained alive. Take any of the versions you like—one thing is certain. Clay was “out-generated.” And when Wyatt told Clay to get the Hell out of town—Allison did so. This irked him and he decided to take his cowboys with him and really shoot up Dodge. A second visit took place and Clay’s ego hit the dust! He was arrested, disarmed and fined for carrying his gun!

Maybe it was this fiasco and maybe it was love, but Clay began to change slightly. Especially when he married his childhood sweetheart. And he became the father of two girls.

Suddenly Clay wanted to keep on living. But now he had to live in his own Hell. Wherever he went might be the suspicious move of an enemy to kill him. Whenever he visited East Las Vegas he would ask young Miguel Otero to go about town with him as a bodyguard.

There’s another version of how he died. Not the one I told you before. According to this one he was returning from one of his trips for ranch supplies. He was driving his heavily-loaded wagon down the steep incline leading into a dry arroyo. His crippled leg slipped from the brake. And the wagon shot down to the bottom of the arroyo. Clay fell off the seat, struck the ground and the heavily loaded wagon passed over his body, killing him instantly.

His wife, daughters, and a few friends wept tears over him. And before you start defending him, how about consulting the victims of his in the various graveyards? He might have been one of the West’s biggest and most successful ranchers for he did have some qualities inside of him. Instead—he was just Clay.

Special Feature

impossible escape

by RICHARD H.

BURGESS



At one time this story couldn't have been considered anything but fiction. We know that all the men at the Alamo died. But recent discoveries by the Texas Historical Society show that there was an escape route, such as our author describes. And if two women had used it, their story might read like this..

DURING the lull in the cannonading, the mission bells, up and down the shallow, wide San Antonio River Valley, sent out their musical invitations, "Time for prayer and thanksgiving. Thank Him for all the good things of life. Time for prayer and medi..."

Suddenly the music of the bells, their invitation, was harshly blotted out by the crash of cannon and the incessant fire of muskets, and the cries of the newly-wounded.

The battle to the North, forming a portion of this chain of missions had been raging for weeks, without an hour's respite

to the defenders of The Alamo. They fought on against insurmountable odds. Today they are outnumbered four hundred to one. Their armament is meager; and their food supply, consisting of parched corn, dried venison and dried beef, was growing distressingly short. But not a man could get out and away from the fortress.

The Texas colonists had incurred the wrath of military officials of The Republic Of Mexico, for they had at one time Mexico's great army to flight; and for a time it appeared that the Texans, would drive it across The Rio Grande—but reinforcements had swarmed to the aid of the Mexicans.

Now that same general, who had commanded the fleeing Mexican army—a general who had all but been demoted in rank, or thrown out of his army—was in command of the storming troops about The Alamo. Needless to say, he was angry, and he was seeking revenge; he had vowed to take the life of every man in the Texas army!

THE COLONISTS had poor equipment and their soldiers

were volunteers from the states. They lacked military training. They needed powder and lead and cannon, and as we have stated food as well as medical supplies.

The Mexicans had all means of harassing an enemy: Noise-makers, ample ammunition and cannon. Trained soldiers, and firearms. Swords, knives, food, and horses, for their officers. Day and night the Mexicans poured in fresh troops. Firing and noise was going at all times—day and night.

Inside The Alamo, many of the Texans were dead; others were sorely desperately wounded and one could hear their pitiful pleas.

"Water! Water!" The Texans had to listen to the moans of their dying comrades, the yells of their newly-wounded; and at times the stench of their unburied dead came to them on the smoke-filled acrid air. They were not allowed one minute in which to bury their dead, or rest from the interminable fighting. Mexican soldiers, fifty deep, swarmed about The Alamo.

Before the Mexicans had made escape impossible, the Texans had sent couriers out. . .

hoping to reach General Houston, somewhere northeast of The Alamo, perhaps on the coastal plain of Texas. None of their couriers had returned, nor had Houston sent help.

THE ALAMO is a strong fort, constructed of thick masonry walls, with a heavy stone wall surrounding the main building, or church. This church was one of a chain of missions, and it formed a part of the east wall of the fortification. There was only one entrance gate. It was to the West of the church and it was strong, made up of native seasoned hard wood timbers.

Inside the high court wall, a walk, or ledge, high along the wall, afforded the Texans protection as they fired on their enemies, for the stone wall extended far above them. Loop-holes were used in the lower part of the wall, and, at regular intervals in the ledge. This was important to the defenders; the wall itself afforded them needed protection, and the loopholes protected them while they fired on the attackers.

In early March, reinforcements had poured into the Mex-

ican camps, and on the morning of March the 6th, 1836, an officer came to Mrs. Wilkerson—the only woman remaining in The Alamo, except for her baby's nurse, a young Indian woman named Sunshine. Mrs. Wilkerson had been allowed to remain, for she was a nurse; the wounded and the sick of the garrison needed her. Her husband, Captain Wilkerson, was one of the couriers who had volunteered to seek General Houston's aid. He had not returned, and outside the walls of The Alamo scaling ladders had been brought up and placed against the stone walls.

The officer said, "Mrs. Wilkerson, Ma'am, we of The Alamo, will die soon—every one in the fort. I have whetted my knife; it is razor sharp. You'll want the baby to go fi..."

"Oh! Oh! Must my precious baby have to di..." Mrs. Wilkerson cried, but she was interrupted by the Indian nurse, who snatched the child from the mother's arms and said, "*Baby no die. Come with me!*"

IN A SWIFT movement she scooped up her pet skunk, hugged it to her along with the

baby, and, taking the knife, they entered what was known then as now as, "The Dark Room."

Inside this room it was pitch black. The women heard the outside bar as the officer dropped it into the supports, and the Indian girl, Sunshine, put the inside bar in place, thus barring entrance to their room. She then handed the baby to its mother and, after a time, she removed two flat stones of the floor and said, "We go down. Steps bad. Hold to me."

They had to feel their way along the broken earth wall, and their feet felt along the steps as they went down into a dark, dank, narrow tunnel. Sunshine dropped her pet and then she felt along the tunnel moving as rapidly as she could in the pitch darkness. Directly they were under one of the Mexican cannons, and with each *wham* of the gun, earth fell from the ceiling of the tunnel. It filtered down their collars, into their hair and eyes, and ears.

Suddenly they came to a cave-in, and they couldn't go farther.

The girl passed the baby to its mother and worked with her

bare hands, using them for a shovel; she leveled the dirt on the floor of the tunnel until she had made sufficient opening for them to push through. She went first, then reached for the baby, and with her in her arms she went on. She could feel the mop of the skunk's tail against her ankles.

Mrs. Wilkerson being larger than Sunshine, had some little trouble in getting through; but she worked desperately, for she knew that the girl and her baby were on ahead of her. If there was any fear in their hearts—fear that they might not get out of the tunnel—neither of them voiced it. The girl was familiar with the tunnel and its dangers.

THE TWO women were accustomed to the hardships of a frontier country and the privations and cruelty of war. Death wasn't new to them. They had endured many hardships together. They knew hunger and fatigue. In a short time, they came to another cave-in and Sunshine passed the baby back to its mother; then she worked again, as she had before. Her hands were torn and bleeding, but she didn't pay any at-

tention to her pain—not until the skunk was licking her hands. Then she pushed him away and continued with her work. When she was sure she could get through, she crawled on hands and knees; then when she stood, she said, "Baby."

She would go on taking the baby with her and the mother would overtake them soon. But if the passage was small, she had to work frantically to get through, and of course she worried lest she get wedged in the tunnel. The women knew that they faced death in the tunnel; but Mrs. Wilkerson also knew that Sunshine loved the baby with all her heart. Hour after hour they went on and on, and finally they came to a place where water dripped down on them. The girl passed the baby to its mother; she felt overhead, then said, "We under river. Logs keep dirt-rock from falling. We drink. Pool here." She guided the other woman's hand to the pool of cold water.

While they were resting, they suddenly realized that they didn't hear the cannon, and Sunshine said, "Fight over."

In their hearts, they knew that all the men of the garrison

had met death, but neither of them gave voice to their thoughts.

THE INDIAN moved on, and said. "From here we go up—not bad—slow climb."

They were tiring when they came to a cave-in that filled the tunnel completely. The skunk couldn't go through, and he was atop the dirt. Mrs. Wilkerson said, "Let me move the dirt. You rest."

"You no get by—tunnel too narrow."

The tunnel *was* narrow, and in its narrowness lay their safety; had it been wider, the cave-ins would have been more numerous. Movement was painfully slow. The rest and the water had been beneficial, and in a short while the baby made her wants known. Mrs. Wilkerson took her and she pulled at the near empty breast, but it was enough for the time being.

The air was polluted with dank and the smell of insects; once in a while they'd feel large rats brushing against their ankles.

On one of the cave-ins, Sunshine felt the tail of an opos-

sum, but she made the opening and let it pass on. It would have been food, but she knew that it might be a mother soon, too—for this was Spring.

Hour after hour they moved on and on and then they came to a pile of shale and broken stone. The tunnel was full to within a few inches of the ceiling! The opening was enough for the skunk and the opossum, but the skunk hadn't gone thru. With the first push of rock ahead of her there was the blood-curdling *whir* of the diamond-backed rattlesnake!

THE GIRL didn't hesitate. She pushed stone ahead of her, and then in a few seconds, the skunk was on ahead of her; in another second, the tunnel was filled with the sickening odor of his musk! Out in the open, the scent is suffocating, and in the close tunnel, the odor was sickening. Mrs. Wilkerson gagged, and the baby cried out in terror and pain. Mrs. Wilkerson placed folds of her underskirt to the baby's face, so that it would act as a filter for her to breathe through. The girl worked as rapidly as her strength would allow.

She lay on her back and used her feet to heave the rock ahead of her; then she knelt and pulled stones under her; and finally she said, "Baby."

The mother passed the baby to her, without hesitation. Sunshine held her close with one arm and with the other she pushed and wriggled until the sharp stones above her cut into her back, and the fear for the baby's life was a bitterness in her mouth. Finally she came to where the scent of the musk was suffocating, and the baby vomited. But the girl moved on and on.

Now she was able to stand up and move a little faster. She was getting uneasy about the baby's mother, when she felt her hand reaching for the baby. Mrs. Wilkerson didn't know that she was cut and bleeding. Her back and her stomach had come in contact with sharp stones as she pulled herself thru the narrow opening in the scent-filled tunnel. She took the baby and she ran her hand over every portion of her soft body, but she didn't find swelling; she knew that she hadn't been bitten by the snake. She was greatly relieved. And in her heart,

she was thankful to God for His care.

THEY TRAVELED for a long distance, and then they came to another place where the tunnel was almost completely filled from the cave-in. . .

The skunk was there to greet her hands, and this time he licked them and rubbed his sides against her hands. She soon had a larger opening and still the skunk was with her. She grew uneasy lest the pet knew of lurking danger on the other side of the cave-in, but she pushed and worked with renewed strength, for she had some knowledge of the distance to the end of the tunnel. Soon she missed her pet, and when they were finally through the cave-in and on their way; and after an interminable time the Indian said, "Cat he been out. Whiskers wet."

She knew that her pet had been to the spring, out in what is now San Pedro Park and swimming pool. The spring there was large at that time, and it is still a wonder for it flows a great stream of cold, clear water.

When the Indian made her

statement the women had, without knowing it, sighed with relief. They might escape!

As they moved slowly along, they were aware of more insects and more creeping animals. The opossum hastened ahead of them and the Indian knew that they were nearing the end of their journey under the earth.

After a long time—hours hadn't meant anything to them, the Indian said, "Tunnel, he end near big spring."

Later she said, "We near end. We be quiet. Many people get spring water."

THEN SUNSHINE'S feet hit broken earth steps. She hesitated, passed the baby back to its mother, and went up the crumbling steps into a thicket of mesquite and prickly pear. She reached down and took the baby; then she held a hand to Mrs. Wilkerson, assisting her to the outside world and level ground.

They dropped to their knees and each in her own way thanked God for their escape. They breathed deeply of the flower-scented air; then they caught the odor of burning mesquite wood. It was sweet

and spoke of a campfire, food and drink.

When they stood up on the embankment surrounding the spring and the tunnel entrance, they saw a smoldering fire near the spring. They mounted the hill to the north of the spring and from this advantage they could look back on the town below them and they saw innumerable fires. One was large. It was near The Alamo.

Snatches of drunken song came to them over the flower-scented air and the Indian said, "Fight over. Men drink and fight over women. Our friends are all dead. We go to my people."

She pointed toward the northeast, then led the way out and up the hill, into the timber towards Austin—where it is now.

The skunk danced on ahead of them, and the baby slept in the Indian's arms. They trudged on and on; and when day was blushing in the east, she stopped in the dense thicket of sweet-smelling cedars. She passed the baby to its mother and then, using the knife, she cut many cedar boughs and fashioned a bed for the mother and her child. This done, she

and her pet went out to find water, and food.

MR.S. WILKERSON and the baby slept, while Sunshine hunted, moving in an ever-increasing circle. Finally, when she was near-exhausted, she found a small spring coming from under a dark lime stone at the base of a hill. She and her pet drank deeply of the cool sweet water and then, after a few minutes' rest, she mounted the hill and from her vantage point surveyed the country round about her.

To her north and east, the land was prairie, dotted here and there with great live oaks. Some of the trees were immense. She went back to a large stone not far from where the spring flowed, and where the water went under the yellow sand. She took her seat and waited for the sun to warm the land.

Two hours later, bees were coming to the wet sand for water. She watched them take their fill, then rise into the still air, circle three times, and head for their home. She waited until three of them had left, all going in the same direction; then she

and her pet went honey hunting. The bee course led her to one of the groups of live oaks. She selected the larger of the trees, and went from side to side of it.

Some of the limbs were larger round than a large man's body, and one of them extended toward the spring, or to the southwest. She studied this limb, and in a few minutes she found the entrance to the bees' home—a knothole on the under side of the great limb.

She climbed an elm sapling under the hole, but it was too flexible, and it swayed away from the limb. Sunshine dropped to the ground, took the officer's knife, slit the bark on the elm and then with long strips of it she made the sapling fast to the limb, near the hole where the now-angry bees were making their entrance as well as their exits. She reached for honey—but the hole was too small; it wouldn't admit her hand. She took the sharp knife and deftly enlarged the hole. She reached for honey, got a handful—but she couldn't withdraw her closed hand. She pulled her hand out, licked it clean of the rich honey and en-

larged the hole until she was able to take chunks of honey in the comb, out of the limb.

She ate of the honey and then dropped to the ground, went to a fallen giant of a tree. The bark was thick and dry. She pried great slabs of it from the log and then she dusted it carefully and again she mounted the secured sapling; time after time she came down with rich chunks of honey. . .

WHEN HER tray was well filled, she and her pet went to their hideout. Mrs. Wilkerson was awake and soon the skunk waked the baby and Mrs. Wilkerson looked at the honey and said, "Sunshine you are wonderful. I need water; then the honey will taste good."

Sunshine picked the baby up saying, "Come."

In a few minutes she'd led them to the spring. Mrs. Wilkerson drank deeply and directly the Indian said, "Eat. More water later."

Sunshine had cut chunks of the honey and now Mrs. Wilkerson ate slowly, savoring the delectable, rich food. When she was filled she let the baby lick some of it from her fingers. It

was then that she discovered that her hands were filthy. She went quickly to the spring, where she washed her face and hands, using the sand to scour them. She tore a square of cloth from one of her undershirts, washed it well; then she scrubbed the baby's face, hands, neck and feet well. As she passed the cloth to the Indian, she noticed the bee stings on Sunshine's arms, face and hands.

"Oh, you poor darling. The bees made you pay for stealing their honey. I'll find some clay, make a salve and put it on the stings; in a little while it will take all the swelling and the pain away."

She pried some clay from under the stone near the spring, worked it up with added moisture from the spring, and when it was a thick paste she applied it to every sting. It was yellow and when Sunshine looked at herself in the clear water of the spring she said, "Red—make war paint. This squaw paint. Wash off soon?"

"Sleep first. Then wash off."

SUNSHINE carried the honey tray back to their hide-

out and Mrs. Wilkerson took the baby. The pet lay down with the Indian girl, and while Mrs. Wilkerson did guard duty they slept.

She waked up an hour before sunset and they went to the spring where she washed the clay off. Her wounds had healed, as had the bee stings. Sunshine smiled and said, "You medicine man. Good."

With nightfall, they were on their way again. This night they made more distance for they were in an open country. Plenty of timber but no underbrush to thwart their movements; there were patches of dense thickets, but they went around them. Daylight came and found them on the bank of a crystal-clear, small stream. The south bank was lined with a growth of willow trees, while up the bank, and back from the stream were thickets of live oak and elm. Sunshine went to one of these.

Placing the honey bark tray on a stone, she went to the river and cut an armful of willow boughs. These she used as bedding for the mother and baby. This done, she went back to the willows, where she hunted until she found a straight second-

growth pole. It was long and flexible, but strong. She peeled it with care, removed the outer dark bark from the inner white fibres, then twisted these into a strong thread; this done, she put several of the twisted threads together, and formed a strong line. She took the snowy line to the mud bank and covered it with black slime—working it in with care. Sunshine pulled on the line until she was assured it had the proper strength, then she carefully formed a noose at one end; the other she fastened to the willow pole, after she darkened the wood with the black silt, from the river bank.

WHILE THE pole was drying, she went to the river, took off her scant clothing which she washed, putting it on the soft green grass in the sunshine. She then bathed with care.

This done, she took the knife and cut long, flexible willow switches. She gathered an armful of them, then she sat in the shade of a live oak and, in an hour, Sunshine had a skirt plaited. She fastened it about her waist, then braided two

straps. These she passed over her shoulders down to the skirt, front and back, secured them to the skirt and she was fully dressed for the wilds—she wasn't expecting company.

With her skirt in place, she picked up the pole and went to a spot where the bottom of the river had been swept clean, and a sort of trail was formed, where all the moss and filth had been pushed, or brushed aside. She picked up a smooth stone and two large fish darted up the trail. They swam swiftly upstream, but in a few minutes they came back, leisurely floating, near the bottom of the river, along the trail.

WHEN THEY had passed out of sight, Sunshine dropped the noose into the water, over the trail; she lowered it until she was sure it was barely off the bottom. She threw another stone into the water, upstream from where her noose was. Two large fish darted upstream; then, in a few minutes, they came slowly down the trail. She was still as a statue, until the larger of the fish got his head well into the noose; then Sunshine yanked back on the

pole with all her strength.

There was a great splash, then the fish was sailing over her head to a grassy spot on the bank forty feet from the river! The shock of hitting the earth took some of the life out of the fish, but as she neared it it began to flop wildly. She pounced on it and then with one jab of the knife, the flopping ceased. Deftly she slit the white belly, with two fingers lifted all the intestines, floats and liver out of their resting place. She sliced off a portion of liver and fed it to the dancing skunk, who ate it with great gusto. She sliced off the gall bladder, then she ate the remainder of the liver, her eyes twinkling as she watched her pet.

With one deft movement of the sharp knife she severed the head from the thick fish and passed it to the waiting skunk; then she picked the fish up, went to a jutting rock, where she dressed the fish, boned it. Then she went to the willows, cut another armful of boughs—their leaves were out, and when she'd wet them in the river she wrapped the dressed fish in them. They were her refrigerator; they would keep the fish

cool for a considerable length of time.

Again she visited the willows and from them she cut a bundle of long slender switches. She sat in the shade of the live oak, ate thin slices of fish and worked swiftly. The sun was high and warm when her work was finished. It was a strong, basket with a loop-like handle; in it she placed her fish. Then she put her clothes in the basket and went to the hideout.

Her friend was awake. Sunshine passed her a slice of the snowy meat and said, "Warm in mouth—then chew. Good food."

MRS. WILKERSON was skeptical, but she knew that she had to have food, if she was to nourish the baby. The touch of the cold, clammy meat was repulsive to her, but she did as the girl had suggested, and to her surprise it was juicy and sweet. She ate the slice and was ready for another when the girl passed it to her. Then Sunshine said, "Water warm now. Bathe. Wash clothes. I bathe baby."

"I haven't clothes to wear while mine are drying. I..."

"Wear these."

Sunshine indicated her clean

dry clothes. There were of coarser material than the lady's, but they were clean and dry. True they were without undershirts, or pantlets, but the Indian hadn't felt the need of more garments. When she did, she'd put on buckskin pantaloons. Shorts to us.

Mrs. Wilkerson undressed by the river, and then she was in the water. She swam with ease, and after a short time she took the baby; Sunshine washed their clothes and spread them on the grass, and the child was delighted to be free from clothing. She gooped, gurgled and laughed, to the delight of the girl and the baby's mother.

The sun was past the center of its travels when the Indian slept.

Mrs. Wilkerson kept watch; the baby slept with the girl. Two hours before sundown they awoke, and Sunshine took the knife, hunted until she found the materials she needed and then she made a fair bow—using the fish-snare for the string. She had cut a number of clean, straight chapparral shafts, notching one end and sharpening the other, and they were armed, ready to kill game that

was plentiful in the woods at that time.

Before they left their camp, Sunshine killed and dressed a fat squirrel. This she put into the basket with the fish. It would keep cool and fresh until they needed it for themselves and the skunk.

DARKNESS was descending when they left the camp. Hour after hour they trudged on and on; and though they were weary, they didn't stop to rest until near daylight, when they sought shelter in the cedars once more. Water was a little harder to find this time, but Sunshine found it...

But as she studied the late tracks about the spring, she wasn't at all sure of herself. Later, when Mrs. Wilkerson saw the tracks, she said, "White men have been here; however it has been some time since the tracks were made. They may be a long way from here now. We aren't in danger."

"Mexican's—they use the hard heeled shoes, too," the girl said.

A little later they moved their camp to a denser cedar break, where they rested until near

night. When the mother and the baby awoke, the girl had dressed quail for them.

The meat was white and sweet, even though it was raw and without salt. Mrs. Wilkerson ate the breast of a bird and at last she relished the raw meat. They ate some of the honey, and then they trudged on.

This was their procedure, and it seemed to the white woman that she just couldn't go another mile, when they were greeted by innumerable dogs. They were friendly but they aroused the whole Comanche village.

Sunshine was happy and proud as she said, "My people. They welcome us. They will take care of us and I'll tell them about our travels and the fall of The Alamo."

Daylight came and she was still telling them of their trip, of the horrible battle in The Alamo, and of the burning of the white men. The village turned out en masse to make them welcome, set their choicest foods before them and they ate till they had gorged themselves. The baby was happy and full of rich milk, too. One of the young Indian mothers

nourished her from her breast, as she nourished her own child. She was husky and strong. And she was happy to nurse the pretty white baby.

They rested in the Comanche village two days and then, since Mrs. Wilkerson felt that she might contact General Houston and learn something about her husband—and at the same time tell about the fall of The Alamo—she persuaded them to let them be on their way.

The Comanches supplied them with their sturdiest ponies, ample food, a blanket and two buffalo robes, and a better bow and many arrows. Two of their ablest warriors rode with them to the next village, near where the town of Bastrop is today. From that village, they were more or less on their own, though they did come in contact with a few other Comanches; but when they reached the fringes of the great coastal plain they were alone—and had been alone for several days.

But to the Indian, her friend was different. She would ride along and sing foolish songs, and then laugh at them. Finally, Sunshine found that Mrs. Wilkerson was burning with fever,

and she recalled that many of the men in the garrison had died from this sickness. From that day on, Sunshine kept the baby from her mother, and all she could feed her was some of the honey and water. This seemed to satisfy her needs, but her mother grew worse and worse.

MRS. WILKERSON was unable to ride. The Indian was puzzled for a moment, and then she went to a nearby clump of young live oaks and cut two of the tallest saplings. She peeled them and then, using a robe lashed between them, made a travois. The poles were held apart by crotches from small limbs of other trees. The small ends of the poles were lashed to one of the ponies, a pole on either side of the animal. This done, Sunshine put Mrs. Wilkerson, and their robe and blanket, in the travois; she herself took the baby in the food basket with her. She lashed the basket to the horse pulling the travois. She mounted her own pony, then unlashed the basket and let the child ride with her. Travel was slow and tiring to the girl, for she felt the weight of her responsibility.

They were out on the plains among the great hedge rows of roses. Some of them are miles long, and at this time of the year they are beautiful. Often the girl made their camp near a hedge; when the showers came, they would have some protection. The rain was always chilling and she was sure that this would be bad for the sick lady. At night, the Indian would bathe the sick lady's face, arms and hands in cool water. She had learned to do that while caring for the sick in The Alamo.

SUNSHINE was all but exhausted when she finally lay down to rest. Mrs. Wilkerson waked her the following morning as she called to two men on the plain. They came slowly toward them.

The Indian was frightened, but when she saw that they were white men, she said, "I have a sick white lady with me. We seek General Houston? Will you lead us to him?"

"Can you tell us the lady's name?"

"She is the wife of one Captain Wilkerson. He left the Ala-

mo many moons ago. He didn't return. We go to him?"

"What will you tell General Houston about the men in The Alamo?"

"They were murdered and their bodies burned. Not a man left."

"Are you sure of your statement? You *know* that they were all killed—*know* that they were burned?"

"We saw the fire. We escaped from The Alamo, the last day of the battle. My people are Comanches. They helped us travel this far. Will you lead us to the general?"

"Indeed we will. We are from the general's camp."

TWO DAYS later, they came to the outposts of General Houston's camp and the guard said, "I'll send a medical officer here. Don't go further. The lady may have a contagious disease. We'll send a tent and someone to care for her and her baby and the Indian girl—unless you want her to stay with the sick woman."

"Get the doctor. He'll decide the thing to do. Do the best for all concerned."

Major Holmes was from one

of the coastal states and he hadn't finished his examination when he said, "She is in the last stages of typhoid fever. Sergeant, it is well that you stopped them here. We'll keep her away from the main camp and we'll sterilize everything she touched; bury the stool and urine. She needs care, and the Indian has been with her a long time.

"We'll send the baby to one of the mothers of the Comanche villages not far from our present camp—but send two soldiers with the girl and the baby, and don't let the child out of their sight any of the time. The Indian mother will covet it; if she has an opportunity, she'll hide it and later claim it's hers. I'll get some brandy to rub on the lady when all the fever is gone; it will be away from her before daylight."

HE WAS correct in his diagnosis. Before daylight, Mrs. Wilkerson cooled, and then she had a sinking spell; it required skill and courage to keep her alive until the doctor arrived. He gave her brandy and had Sunshine rub brandy on her wrists and her temples.

The doctor had one of the men build a fire, then he put water on to heat. He didn't dare give but a sip of brandy at a time, for it had been days--yes, weeks--since the sick woman had had really solid food.

Until ten the following morning, they worked with the patient. When she was out of danger, Major Holmes said. "Sunshine, you are a splendid nurse. Your care has saved her life, and that of the baby, too. If you'll go with the men to the village of the Comanches, and find a young mother she'll nurse the baby until she—is able to take solid food." He pointed to the mother of the child.

It was an hour's ride to the village; when they arrived, the women—and some of the men—made a to do over the white baby. Then Sunshine made her needs known, and in half an hour a proud, happy mother nursed the white baby along with her own infant.

This was a daily task, and often when the baby got fretful, Sunshine would get her pony and ride to the Comanche village and the baby would be well nourished again. But as the army moved along, and Mrs.

Wilkerson gained strength, and they got farther from the Comanche village, feeding the baby was more difficult.

Sunshine finally succeeded in persuading the Indian mother to travel along with the army, assuring her that her husband would be used by the army.

Mrs. Wilkerson was delighted, and as she improved she asked many men of the army about her husband; but it seemed to her that they all turned from her without giving her an answer to her questions. Time went on... the sick of the army were placed in horse drawn ambulances and they, too, moved with the other men. Mrs. Wilkerson was allowed an ambulance for herself and her two Indian nurses, for her care was in the hands of Sunshine.

MRS. WILKERSON - improved for a while; and then, for some unknown reason, she became listless. The amount of food she ate wouldn't have kept a child alive.

Sunshine said to Major Holmes, "She no eat. She mourn for Captain—her man. Find him—she get well."

Often Sunshine reverted to broken English and she spoke like a half-civilized Indian; however, after this talk, Major Holmes went to the general.

"We are about to lose Mrs. Wilkerson, unless—we must tell her about her husband. She has a right to know about him."

"You are correct. Today, within the hour, I'll go to her tent. We will not break camp for, well—perhaps the war will be over when we leave our present camp. See that she is made comfortable. See that she has sufficient help to take care of the child and her nurse."

Many men of the camp had been asked over and over, "Have any men of this camp made contact with Captain Wilkerson? Do you know if he's been found? Tell me about him."

EVERY DAY and hour Mrs. Wilkerson asked her questions, but today when an ambulance drew up at her tent, she merely thought they were on the move. She was ready to begin preparations when Sunshine said, "General Houston is here."

"Good morning, Mrs. Wilkerson. Ma'am, I'm Houston.

I'm happy to know that you are improving and..."

"General Houston, it is nice of you to come to my humble tent, and I thank you. I'm better and—tell me sir, have any of your men found Captain James Wilkerson? He volunteered to ride out from The Alamo, seeking your assistance. He did not return to us. Do you know where I may contact him? Please?"

"Mrs. Wilkerson, ma'am, you have been very ill. You are improving, and you'll have to experience another shock. I have to tell you that many weeks ago my scouts brought your husband, desperately ill, into our camp. He had a raging fever, and he has lingered—on the brink of eternity, and..."

"Take me to him! Please. He needs me! I want to go to him—now! I am a nurse. He needs me! Hurry!"

"Mrs. Wilkerson, Ma'am, I have to warn you. He isn't the man you know. He is nearly a skeleton. He had blood poison, in his right foot. My surgeons had to remove the foot. Later, they had to remove a portion of the leg. He is a very sick man. He may not sur..."

"Where is he? Why don't we go to him?"

"I warn you it will be a great shock to you, Ma'am. Come with me."

GENERAL HOUSTON assisted her into the ambulance. The driver knew where to go and in twenty minutes they stopped and instantly the general was out and assisting the lady to the ground. They went into the tent. There on a pallet, lay a thin, bearded man. The bed was dry grass, covered with coarse blankets. The weather was warm...he was without cover, and his stump of a leg, swathed in bandages was visible.

General Houston assisted the lady to a low, hand made stool, then he turned to Major Holmes with, "She's a strong personality. You will take special precautions? Use all your skill to protect her, please."

For a time she sat motionless on the stool and then suddenly she cried, "Surely this isn't Captain Wilkerson? He—He—Couldn't—Darling—"

She left the stool and literally staggered as she went to the

pallet, and dropped down beside the sick man saying,

"Jim, darling, this is your Molly! We, your girls, are here with you. We need you and you must get well! You have to help in—in the fight for Texas."

She wept bitterly as she tried to make the man hear her...

Finally his eyes opened, and it seemed to all that there was a look of recognition on his lean whiskered face; for an instant, a lifelike light came into his eyes. A smile came onto his face, and he sighed heavily... then he relaxed in death, but the smile was still on his face.

Mrs. Wilkerson wept bitterly, and after a time the Major Holmes gently lifted her from the stool and helped her to the ambulance. Back in her tent, he gave her a mild sedative and gently he lowered her onto her pallet. A pallet much like the one the captain had used.

THAT DAY, the news of the Captain's death, and the fall of the Alamo went through the camp like wildfire. The men digging the grave for the captain vowed vengeance on the whole of the Mexican army.

Then, the day of the captain's funeral the whole of the army were aroused; and later in the day, after the last of the military funeral, Mrs. Wilkerson went to the general saying. "Sir, Captain Wilkerson, gave his life for Texas. I was in the Alamo, a few hours before it fell. I saw the fire that destroyed our dead patriots. We must win the battle that is coming soon. I want the privilege of talking to the men of our army—please."

"Mrs. Wilkerson, Ma'am, you are overwrought at the moment, and that is understandable. Now in a few days—if all goes according to plan—I will be happy to have you speak to our men. The battle that is to be—shortly—will be our last. We either win or we lose our all—but we will win—with His help we will, and I am assured of that. Before the battle, you will speak to our men, I assure you."

Day after day the heroism of the captain and his lovely wife, and the dastardly deeds of the Mexican army was told and retold; and each time the story was repeated, more anger, more hatred went into it. Feeling against Santa Anna, and his

vast army was worked up to a high pitch.

WHEN WORD came to the camp, got around to every man in the army, that the Mexican army was approaching from the direction of San Antonio, and that the same general was in command of it—the general who had ordered all men of The Alamo be killed and their broken bodies burned—when they, the men of the army got this information they were ready to meet the enemy, and the day of the fight—early morning it was, Mrs. Wilkerson was allowed to address the men; and she said in part this;

"My friends, and neighbors. I greet you, and speak to you in the belief that today we'll win our right to independence for Texas and our colonies. The right for self-government, unhindered and unhampered by the little men from south of The Muddy River. Today is our testing time. We are going to battle our most ruthless enemy. A hated enemy—an enemy who would gladly cut the throats of your innocent wives and children. An enemy who would gladly kill you and then laugh



as they burned your body, and the bodies of your comrades. Remember the Alamo, and the Goliad, when you are before them and shoot to kill! Don't let one of them escape. And we ask God's blessings on this fight. Lead us—every man to do his best. The time to fight is now! Go, and win!”

The Houston scouts had come in with this word,

“Our Comanche friends have allowed the Mexicans to kill many cattle. They are full of roast beef and wild onions. They rest and sleep. Their guards will have arrows through them within the hour. It is our opportunity. We will be upon them before they know we are near them. We must strike now!”

At a given signal, General Houston's army moved out, under cover of the low banks of a bayou. The Comanches, would attract the attention of the enemy towards their village—then all would turn on the invaders. The Indians would use their flaming arrows to destroy supplies; the Houston army would kill the soldiers. Their plans and men were well organized and each man was fully aware of his place in the fight.

THE ZERO hour had come! The signal for attack was given and the men surged forward, yelling as they ran. Within range, they made every shot count. The Mexicans fell rapidly and the Texans yelled, “Remember the Alamo! Remember Goliad! Kill the Little Devils! Don't let one escape!”

The Texans would not be halted. The Mexicans fell to their knees screaming, “Me no Alamo! Me no Goliad!”

Many of the Mexicans dropped their arms and headed for the West, to be felled by Comanche arrows. The battle was of short duration, and the Mexicans were happy to surrender, lest they all perish.

The Texans were for killing every man of them but their wise general said, "Gentlemen: From this day forward, we are a nation, free and independent. We cannot kill men, ruthlessly, after they are our prisoners of war. Their general is sorely wounded. He is suffering from infection in his broken leg. Our surgeons will amputate the infected leg. But we will let him live until God sees fit to rid the world of him."

Many of the soldiers were displeased for they had it in their hearts to kill Santa Anna; but later they realized that their general was wise. He had done the right thing, in letting the conquered general live.

Through the kindness of General Houston and his men, many of the Mexicans remained in Texas, and were of great assistance to the colonists—for they knew they didn't dare return to Mexico, lest they be killed by the nationalists. They were helpful to the colonists in clearing land of brush and pear thickets. They assisted in fencing much of the farm land of the colonists, and they were willing workers. Yet there were many of the colonists who

wouldn't allow any Mexican on his property. That is, of course, a thing of the past; today, men from Mexico render valuable service, not only to Texans, but to the nation as well.

What was that question General Houston asked of Sunshine? It was this, "Sunshine, why didn't you tell the men of The Alamo, about the escape tunnel? Let them escape too?"

"While fight on, tunnel end guarded. Fight over—soldiers, they drink and fight over their women. Tunnel end unguarded—we escape."

Several years ago, Texas Historical Society, was having many of the missions about San Antonio, restored to their original form, and it was during these operations of restoration, they found tunnels; and though some of them had been filled in completely, they are certain that at one time, all missions were connected by escape tunnels, and at least one tunnel was found to go under The San Antonio River.

So we see that impossible escape, was possible, for three people and a little pet skunk!



deadlands

justice



by **ELTON**

WEBSTER

Too late, Witchitaw discovered why Ashley was willing to pay him so well for trapping the king of the wild horses.

WITCHITAW was afraid—more afraid than he ever had been in his life. Even more afraid than the last time the Sioux staged a violent insurrection, when the dulled edge of a tomahawk had nicked his right ear.

For Witchitaw was going East—far East all the way to New York—to shoot a man in the back. The front wouldn't do; it had to be in the back. There was no other death that the man deserved.

It made Witchitaw uncom-

fortable just thinking about it. He had killed seven men—not counting Indians—and always the slug had come *out* the back. For No. 8 the code ordained the bullet should go *in* the back and come out the front.

Like his hair, Witchitaw's long mustaches were gray and straggly. They drooped more disconsonately as the wheels of the Great Northern clacked and cinders rained through the open window of the day coach.

He wore a tight-fitting suit and vest and his spindly shanks made his trousers, pushed into scarred high-heeled boots, billow when he walked. No matter how often he knocked his sombrero against his leg the red dust of the Deadlands lingered upon it.

He wasn't sure how old he was, but he must have been close to seventy. It was duly recorded that in 1888 he had married a squaw near the national cemetery where Custer and his men slept.

In all those years, Witchitaw had never deliberately set out to kill a man. Such things happened almost spontaneously—and lawmen usually understood

that it couldn't have been otherwise.

But this was different. Witchitaw doubted very much if the New York police would understand why he had to kill Ashley. They might think there was something illegal about it. There wasn't. Ashley had done a helluva thing—and still was making a fortune doing the same thing over and over again.

★ ★ ★

JUST THINKING about it, Witchitaw moved his head somberly. He recalled the first time almost two years ago when he'd met Ashley on his spread thirty miles from Billings. His ranch was big, his cattle many.

Witchitaw had sensed immediately that Ashley wasn't a cattleman in the true meaning of the word. He looked like one, acted like one; only his booming laugh was too ready and behind its heartiness was something that Witchitaw could not place. He later found out that the word for it was sardonic.

Now, meeting him again, Ashley greeted him effusively. "You're famous in these parts, Pop," he said too smoothly. "They tell me you're the best hunter in the Deadlands."

Witchitaw nodded. "I'm fair-to-middlin' I suppose. Why?"

"I want you to get the Old Codger for me."

Witchitaw rocked back on his heels, staring in amazement. He straightened and spat deliberately. "The Old Codger knows more about the Deadlands than I'll ever know. I've been trailing him—and losing him—for nigh onto twelve-fifteen years. He's the greatest hunter in these parts."

"I know that," Ashley said impatiently. "That's why I sent for you; you know his moods."

"Shore do," Witchitaw said enviously. "He takes what he wants, young or old. But he shore as hell is choosy sometimes. He's smart."

"Hell!" Ashley snorted. "He's just a horse."

Witchitaw shook his head. "No he ain't. If there's a horse god he's damned near it."

"Poppycock. He's just an old scavenger. He raids and takes off the best mares and fillies. His is the biggest herd in the territory. Without him the herd will stay in the hills in winter."

"Horses got to eat," Witchitaw said laconically, looking

suggestively at the big paunch on Ashley.

ASHLEY avoided Witchitaw's eyes. "When snow gets deep my cattle have trouble getting forage. If the wild horse herd gets there first there is no food. My cattle starve even though my riders and wagons bring hay to them."

Witchitaw nodded understandingly. Grass, feet deep under hard snows, was precious. It was an old complaint of all ranchers.

"Puttin' a rope on the Old Codger is goin' to be quite a job." Witchitaw muttered. "He's smart. I been trying for years and never got close yet."

"You won't have to do it alone. My men will be there to help. Can you tell me where he will be a month or six weeks from now?"

"Nope."

"Do you know where he is now?"

"Wouldn't be surprised that I do. His custom when Winter is nigh is to start driftin' out of the Deadlands, through the Badlands and onto these Montana flats. He stays hidden right on the edges until snow forces

him into the open. Right now he's probably holed-up between thirty and sixty miles above Deadwood. It'll take some huntin' to find him."

Ashley's eyes glittered. He opened a fat wallet. "One hundred to haze him into the Matache—paid in advance." He thrust bills into Witchitaw's hand. "And one thousand bounty to you for getting the Old Codger personally."

"He'll be dratted hard to put a rope around," Witchitaw hedged. "I been close enough to him three times to try it. He outfoxed me."

"You were that close?" Ashley said incredulously, "and you let him get away?"

"Sho. What else was there to do?"

"Shoot him!"

Witchitaw looked his disbelief. "Shoot him!" he said incredulously. "Why a man don't shoot a horse in these parts onless said horse is hurt so bad that he's helped by being shot. An' no hunter would ever think of shootin' the Old Codger."

"Why?" Ashley snorted.

"Because," Witchitaw said simply, "he can't shoot back."

Ashley looked past Witchitaw

at his foreman, his face knitted in concentration. He knew he had made a mistake; he had heard of old timers like Witchitaw with codes as old as the West itself. But perhaps it wasn't too late to get wily Witchitaw on the payroll...

BEETLE-BROWED Blackie Branca's boots kicked up dust as he sided almost silently near Ashley. His too-red and mean mouth made a fleeting smile at Witchitaw.

Witchitaw looked steadily down at Branca, and did not like what he saw. Just a few short years before, Branca had been generally regarded as a small-time rustler; and he had never bothered to deny the rumor. Then Ashley had showed up and bought a spread, and overnight Branca had achieved a respectability of sorts as foreman. To Witchitaw that move had never made sense.

"Couldn't help overhearing," Branca said, winking covertly at Ashley. "There's the right way and the wrong way to do things here. Mr. Ashley doesn't understand that yet. The Old Codger would be more valuable to us as a ranch stallion than a

dead raider. We want him alive."

Witchitaw watched Branca's little eyes forcing themselves into a bland stare. Success was not achieved. Something was wrong here, something difficult to decipher.

Ashley said heartily. "Branca's right. We want him alive and we want some of his mares. He's st o l e n a lot of top hoss flesh. I want to own the mares and some of the better colts. You just haze the herd somewhere near here where Branca and my men can get a rope on a few of them."

Witchitaw hesitated. There was an inner whisper of warning, but the answer wouldn't come. The explanation made sense. The Old Codger was probably the greatest range stallion in the country, and his harem was elite. The herd itself would be worth many thousands to any ranch owner, not counting how much grass could be saved from the sudden and devastating raids of the wild bands.

Witchitaw said: "It's worth more than one thousand." He was thinking it was time he settled down. He had three hundred in the bank at Billings and

he needed to settle down. A man can't make his saddle his seat, his pillow and his home forever...

"Hell, boss," Branca said. "It's worth plenty to get them in a blind where he can pick and choose. We need a top remuda."

Ashley looked at Branca and peeled off another hundred dollars. "Two hundred to haze the Old Codger into the Matache—and two thousand bounty if we get the Old Codger."

Witchitaw made a whistling breath. Here was twenty-two hundred dollars, enough to give him independence for life. After all, he was somewhere around seventy, and the trails were getting dim at times.

HE TOOK the hundred. "In the Matache early in August," he said. "Keep your lookouts posted. You can't miss it; it's a big herd an' I won't be drivin' it fast. Jest doin' a little bedevilin'. I think I can make the Old Codger try to make a run through the Tahita Pass."

Ashley gripped his hand warmly. "That'll be good enough. My men will be wait-

ing on the far end and close in after you from the rear. We'll get the Old Codger."

Witchitaw shook his head doubtfully. "Don't gamble on it, mister. He's smart. Like I said: 'If there's a god among horses he's damned near it.' You're just human."

IT WAS AS Witchitaw had expected. He rode into the Deadlands, and in every pass among the gaunt rocks were tracks. Some came around the abrupt bends: others came out. And, for an amateur, an endless ride would always bring him back to his starting point if he were lucky enough to recognize it as such.

That, too, was difficult. All draws and passes and rocks looked the same except that the moody sun suddenly would disappear and shine again contrary to directional expectations. When it should be before you, it was behind; when it should be to your left it would bafflingly glitter to your right before fading again.

Witchitaw rode almost unerringly around the numerous bends. He scorned ascending the rock crests. That would

have been utterly baffling to a new comer. The disconsolate rocks would stretch endlessly in almost similarity in four directions. It was the original Never-Never Land. (Never-never to come out again. Witchitaw had labelled it years before.)

There were springs in there, but it took a smart man to find them. Riding due North, Witchitaw looked and drank at three—and patted the mare reassuringly. There was fresh dung miles from the fourth. That made Witchitaw grunt in satisfaction. He veered away, riding Northeast.

Hours later he swung off the mare and climbed stiffly up the rocky side of a horseshoe-formed rock. His progress was agonizingly slow. He realized anew that Ashley's offer was a good one. He was becoming too old for this; it was time he settled down. There was two hundred in his jeans, three hundred in the bank in Billings, and the two thousand bounty on Old Codger's head. That was the kind of security a man wanted when he couldn't manage any other sort anymore.

As he had guessed, there below in an amazing expanse of

green shrub growth—a defile of the North Atlantic wind currents—was the herd.

Flat on his stomach, peering from behind a boulder, Witchitaw looked down. As a stone drops—flying forward—Witchitaw could have spit on the Old Codger's head one hundred feet below.

HE LOOKED as usual—kingly and domineering. Perhaps it was the shadows of the draw, but Witchitaw thought he spotted grayish blotches in that once-rough sorrel hide. The neck was still arched proudly and the cream-colored tail and mane flowed long and briars mangled and curled them as though to affront all conventions. His nose was scarred from bites and there were black patches on his legs from vicious kicks of too-ambitious younger stallions. There was a gauntness under his high-power binocular eyes, but his heavy muscles hid the hunted hungriness of the Deadlands.

Witchitaw looked at the rest of the herd and softly whistled. He moved with the soundless-

ness of a lizard to another boulder to look and count again.

In the small oasis they nibbled futilely at grass roots, some stunted, all hungry. They had to move soon. Witchitaw noticed with surprise that a half-dozen young stallions roamed on the fringes.

“Old Codger knows he's slip-pin', I guess,” Witchitaw told himself. “Hired himself some assistants who ain't too ambitious.” He looked again at the herd that numbered more than he could count—maybe three hundred or more.

“Biggest damn herd in all creation,” he mumbled. He looked in admiration at the Old Codger. “You're a real hunter, pard,” he muttered. “You robbed and you've fought and you've raised one helluva big family—and in the Deadlands too.”

HE MOVED soundlessly back to his first boulder. Then he spat deliberately.

Old Codger snorted, wheeled and looked upward. Slowly Witchitaw came erect on his spindly legs and looked levelly at Old Codger.

The long tail swished as if in

greeting and the nubs of ears cropped by many far below zero winters twitched forward.

For a moment he seemed unafraid of Witchitaw, welcoming him as one of the Deadlands own, a foe worthy of all his wile.

Witchitaw felt his old heart pump in sudden pride. He knew the Old Codger recognized him and respected him. It was good to have someone respect you.

"Been three years since I saw you before, pard," he said aloud. "Three times you won; this time it's my turn."

At the sound of his voice the heads of grazing horses had lifted. They stood in indecision.

Old Codger's ears went back until he looked like he had none at all. He whirled suddenly, his tail high and waving at Witchitaw, and made a sound the like of which Witchitaw had never heard. It wasn't a snort; it wasn't a whinny; but more like the clear notes of an urgent bugle.

The herd took off, bending to the rocks winding due South.

Witchitaw stood on his lofty pinnacle grinning and chewing the straggly ends of his mustache.

At the far end of the oasis, Old Codger, the last to make the turn, turned and looked speculatively at Witchitaw.

Witchitaw made a great show of apparently hurrying down to his mare.

When he reached her he mounted slowly, and walked her cautiously around the rocks, weaving interminably in and out, until a half hour later he ascended to the oasis. There was still a little water in the spring, and Witchitaw again gave credit to the Old Codger for being a real overlord to such an immense herd. Rationing had been in effect.

He hobbled and unsaddled the mare, unrolled his bed roll and went peacefully asleep with his head on the saddle knowing the Old Codger would be hazing his herd in full flight the whole night long, the next day and night, and the night after. Then they would meet again.

AT DAWN he rode North, directly opposite from the Old Codger's line of flight.

He pushed the mare slowly and insistently for two days, conserving her strength and gradually bending to the North-

west. Then in the darkness that night they turned South.

When close onto the flats near the edge of the Badlands, Witchitaw dismounted and wearily climbed to the heights. His old eyes squinting in the unaccustomed bright day looked baffled. Below was desolation, intense and foreboding. He had expected a small dust cloud in the distance. It looked like the Old Codger had lived up to his name and outfoxed him again. The stallion always had been a great one to head far in one direction and then turn abruptly around without reason and return, but always drifting West. To the East was wire and to return to the Deadlands with Winter coming on was suicide. To the West were the deep snows but little wire. And under the padded snows was grass. . .

Witchitaw snapped the fingers of his calloused right hand in agitation.

"I'm just a plain damned fool," he said aloud.

He returned to the mare and that night pushed her hard in an almost straight line for Neill's Creek that flowed tantalizingly close to the Badlands.

He'd expected the Old Codger relentlessly to drive his herd past two water holes and make for the third in an abrupt backtracking. But the Old Codger must be desperate. He'd bypassed three holes to head West in a long, steady and exhausting drive.

Witchitaw could imagine the younger colts tottering unsteadily on their spindly legs and the heads of the mares hanging low in utter tiredness.

Witchitaw had them, he thought, if he could keep them from resting. None of them—not even the Old Codger himself—could go on forever.

His thin shanks pounded an insistent tattoo on the mare's sides. She was making a hard run but nothing comparable to that of the herd despite the weight she carried.

THE SUDDEN flushing of the herd near dawn above the water hole just fifteen miles from the Matache took Witchitaw by surprise. Grudgingly he admitted the Old Codger almost had foxed him again, permitting the herd to drink and then driving it North instead of West on the edge of the Badlands where

there was no forage and the herd logically shouldn't have been expected to bed down.

He was making the bend through a narrow rock defile when he heard the shrill whinny of warning almost directly in front of him. There were sounds of an uneasy shifting like an army aroused from deep sleep. Then hoofs started to pound until they reached a crescendo, going in planned flight West.

Listening, Witchitaw knew he was on the Old Codger's trail. This was a huge herd. There was no doubt of it.

That started the game of hide-and-seek, the brains of the two greatest hunters in the Badlands pitted against each other.

Witchitaw would drive forward on his weary mare, then baffling swing far to the North or South and be waiting for the herd to come up or down accustomed paths. But always the herd went West—t o w a r d the Matache.

ON THE THIRD day the herd was hazed into the open flatlands. Old Codger had no choice now. He had to make a run for it. The blue-green hills of the Matache lay far in the

distance. There was food there and a sanctuary of sorts.

Witchitaw rested his mare and looked again in amazement at the huge dust cloud the many hoofs made. On the fringes he could see the Old Codger, his neck still high and his tail flowing, biting, kicking and hazing the weary stragglers. Again Witchitaw felt a grudging admiration for the great horse. In his steady and violent patrols behind the herd he certainly must have ran more than twice the already killing distance Witchitaw had forced the herd to take without pause for food. Yet he seemed to draw on some secret well of energy, an indomitable will to protect his family. The pace he was setting seemed staggeringly swift. Witchitaw found his mare dropping behind, her head sagging far forward, her feet stumbling unsteadily at times.

The dust cloud drew into the distance, but Witchitaw was satisfied. Old Codger was driving it straight for the Matache. There the Old Codger expected to lose Witchitaw in the blinds and draws once he'd gone through the pass.

Witchitaw guessed that the

pass might be open, with Ashley's men not there. He was exceeding calculations. The flushing of the herd had come faster than he'd expected.

But Witchitaw knew a deep and inner satisfaction. He'd outfoxed the Old Codger this time. If the Old Codger got his herd safely away through the Matache, Witchitaw would simply raise his hand in salute, a brief hosanna from one veteran of the Deadlands to another. The Old Codger played the game like Witchitaw—brutal and hard and fair, using every wile at his command. . .

Witchitaw pulled his mare to an abrupt halt. He stood in the stirrups, his scrawny neck bent forward.

The herd was turning, milling in panic. In the distance Witchitaw thought he saw the dusty forms of horses fall, before others plunged recklessly ahead.

Witchitaw's spurs raked the mare's sides. She grunted in protest and broke into a laborious lope.

It seemed to take agonizingly long hours to cover the distance before Witchitaw saw the first

dead horses. Some were still, others trying futilely to rise on shattered legs. Bullets had riddled their hides with reckless abandon.

Witchitaw carefully made sure all horses were dead—carefully shooting four wounded horses—before mounting the mare and again driving her forward to the mouth of the Matache.

THAT SUCH a thing should occur was past his understanding. Nobody gunned horses in these parts. A horse was a god. Without a horse the West never would have been built. True, oxen had helped somewhat, but horses had kept the West an alive and breathing thing.

The dust cloud was gone, and if there was one inside of the Matache, the rimrocks obscured it. Witchitaw felt an ominous premonition that there was no dust cloud, that the herd had stepped into a devilishly-conceived trap of some hybrid that called himself a man.

And Witchitaw felt guilty. If there had been a trap, he—Witchitaw—had driven the Old Codger there, and that certain-

ly was no way to treat an old pard who respected you as much as you respected him. . .

The sharp whine of a high-powered bullet passing overhead shocked him out of his musings. He pulled the mare to a stop and his keen eyes sought the rimrocks again. The ragged crags looked innocent and serene enough.

He thought he heard the racketing of quick shots in the pass and the squeals of terrified horses. But he couldn't be sure.

The mare gave a sharp grunt and wobbled forward a few steps. Only then did he hear the sound of a shot. He had his right leg in the air and was stiffly dismounting when a pile-driver hit his left shoulder and knocked him clear of the falling mare.

Rage fought pain in utter bafflement. He crawled painfully across the narrow stretch to the protection of the feebly-kicking mare. Witchitaw shot her in the head and when the legs were still he crawled close to her protecting belly using her body as a shield against the menace of the rimrocks.

Lying there, breathing heavily, the enormity of what had happened occurred to him. He had been ambushed, coldly and deliberately, without apparent rhyme or reason. And for why? Certainly it wasn't that Ashley would rather kill than pay out a piker's two thousand bonus for the capture of Old Codger.

Thinking about the Old Codger, Witchitaw cursed silently. It seemed certain that he—Witchitaw—had driven the old fellow into some sort of a trap for which Old Codger didn't have a chance to defend himself. There had been no fair play in the whole deal, Witchitaw felt positive.

THE SUN rose high in the heavens as Witchitaw silently scanned the rimrocks. The sun was far to the West before a mounted man came out of the pass onto the flats and cautiously approached the dark blot of the slain mare.

Witchitaw's gnarled hand tightened on his six-gun. A high-powered rifle lay across the rider's pommel and glinted ominously in the sun. Witchitaw lay tense, his shoulder a throbbing pain. The slug appar-

ently had struck just above the armpit and left a jagged and clean wound without touching bone.

As the rider neared, Witchitaw grunted in satisfaction. It was Ashley's foreman, Blackie Branca. Witchitaw knew then that he had been duped into flushing the Old Codger—and on accepting the job had marked himself for murder.

Witchitaw saw the rifle raise, level down on him, and heard the thud of the slug bury itself into the mare's body.

Witchitaw held his fire. The range was too far for a six-gun.

Apparently satisfied that Witchitaw was dead or unconscious, Branca abruptly wheeled and started back to the rimrocks.

"Playin' it safe," Witchitaw muttered. "Damned lousy murderin' coyote."

When dusk descended, Witchitaw unloosened the canteen from the saddle and started painfully on foot across the flats.

It was a long walk but he was safely in the protecting hills when the sun arose. He angled up a steep grade that would put him on top of the rimrocks.

There he could look down into the pass and from that vantage point might get an answer as to Old Codger's fate and why a murder ambush had been set for himself. He could think of no plausible answer. This was something new in the grim history of the Deadlands...

HE KNEW of one safe hiding place halfway down the pass, a narrow defile in an apparent blind that offered the only outlet from the pass when the entrances were blocked. It wasn't more than three feet wide at its widest point and a sheer path led to the top of the rimrocks hidden behind the protecting rocks.

He thought Branca might have found that narrow entrance and from the height had set up his shooting gallery. If so, Branca was smarter than Witchitaw had given him credit for. Very few Deadlands hunters had ever discovered this almost invisible break in the rocky walls.

At its top was a plateau no larger than a good-sized rug a man might use on his parlor floor.

Witchitaw avoided the path

hidden even to his trained eye and made his painful way along the top of the rocks. where he could angle into the plateau from above and then look almost sheerly down into the pass. He was weaving dizzily in the hot sun, his shoulder a swollen and festering thing when he finally dropped to the grassy ledge of the plateau.

Back near the wall he heard a snort and his hand streaked to his gun, then paused. The Old Codger was pressed flat against the wall, his proud head lowered, his tail hanging disconsolately. He reminded Witchitaw of pictures of fighters he'd seen after they had fought a bitter and heartbreaking battle. His ears were back, his teeth bared, but there was indecision in his dulled eyes.

WITCHITAW made a soft reassuring sound in his throat. Old Codger still looked undecided. Witchitaw tottered to the edge of the rimrocks and looked down. Then he abruptly backed away and sat down flat on the plateau, holding his gray head in his good hand.

He moaned softly and crawled to the shade of the wall

and lay flat on his back. Tears coursed unashamedly down his cheeks.

Finally the horror of what he had seen dulled and he slept feverishly. The Old Codger took a limping step forward, then backed again against the wall, resting his whole weight upon it.

The pair slept in a small, friendly world of their own making, but high above the brutal world as represented by mankind.

Witchitaw awoke during the night and crawled to the edge and looked down again. The ghouls still were working feverishly. The huge herd lay in a piled and bloodied mass. Every horse was down although some were making futile attempts to rise. These wounded horses the men disregarded, permitting them to live in helpless misery.

In the light of the bonfires Witchitaw could see the heavy wagons piled with the horse flesh and horse hides. Each horse was being butchered with the trained skill of a surgeon. The long cutting knives flashed in the light of the flames, skinning and dismembering with sure and swift skill.

Perhaps there were twenty men. Witchitaw wasn't sure. But among them he failed to locate either Ashley or Branca. They were the ones who had conceived this horror; the ghouls at work simply were stooges.

Witchitaw crawled back to the wall again, knowing a futility he never had known in his life.

Why should anybody want to kill and butcher an entire horse herd? It was not just to protect the precious grass. If that had been all there would be no need to butcher the horses and cart them away in heavy, blood-soaked wagons. Vowing vengeance, Witchitaw dropped feverishly asleep again.

THE THUD of a boot against his leg brought him awake.

Branca stood above him, his rifle pointed downward.

"You're tough, old timer," he said, "but not tough enough. I thought I got you yesterday. Only now it looks like I hit the jackpot by not killing you." He made a negligent gesture to where the Old Codger stood against the wall, unmoving. But his croppy ears were back and

his teeth bared. Through sick eyes he was glaring at Branca's back.

"We got what we wanted—the herd—and now it looks like we got what we didn't expect to get alive—the Old Codger. He was the only one who got away. I saw him over near the wall when the shooting started—and then he was gone like a ghost. This morning I found that little break in the rocks and followed the blood on the trail up here." He grinned mirthlessly. "But I didn't expect to find you."

"Why—why..." Witchitaw began in puzzlement, getting groggily to his feet. The plateau seemed to be tipping and swaying under his feet.

"We got almost a quarter million pounds of good, prime hoss meat," Branca said. "Only we knew a sucker like you wouldn't like the way we got it. Ashley and me figgered it best to keep you quiet—permanently." The rifle was rising and almost touching Witchitaw's thin chest when he threw his right hand to his left and spun right. He felt his hand touch the rifle and push it away. With the motion he reached for his six-

gun—knowing he didn't have a chance. The rifle was swinging around to cover him before his hand had touched his holstered gun.

THEN, miraculously, Branca was spinning out into the plateau, helplessly surging toward the sheer cliff. He was still clutching his rifle—his face set in terror and amazement—when he disappeared. Witchitaw heard his shrill cry briefly. Then there was silence—deep and ominous.

Witchitaw made his eyes focus. They were like hot coals in his head. Old Codger was before him, tottering on his left foreleg, his right still upraised. Witchitaw knew instinctively that he had surged from the wall in an attempt to trample Branca with one forefoot. The first vicious blow against his back had sent Branca tumbling over the precipice.

Old Codger looked speculatively at Witchitaw, and gradually his flattened ears came erect. Witchitaw had passed muster...

Witchitaw noticed then the bullet holes in the left foreleg. Of the three one had shattered



a tendon, but the bone structure seemed firm enough.

Witchitaw got his canteen and poured water in his battered hat. When he approached, Old Codger snorted and backed limpingly away. Witchitaw placed the hat on the ground and went back to sleep.

Later Old Codger cautiously approached Witchitaw and sniffed. Then he sniffed the hat and finally drank. Then he, too, went back near the wall, sagged against it with his weight off his wounded leg and went to sleep.

FOR DAYS they made a strange pair of Deadland waifs—two sorely-hurt animals who understood each other. Old Codger couldn't walk the steep path leading down into the pass. By a supreme effort of will,

Witchitaw made the trip, bringing back water. Then it came Old Codger's turn. He'd been able to live on the sparse grass and gather strength; Witchitaw had not. Daily he became weaker until finally he knew they had to get below. He started Old Codger down the trail, clinging to his tail.

Once in the pass he tried to mount Old Codger, but no man ever had ridden Old Codger and they say to this day that nobody ever has. He suffered Witchitaw to cling to his tail, sometimes dragging him as he limped ploddingly forward across the flatlands.

Witchitaw doesn't know how he got there, but one morning Tim Shane found him outside his cabin in the dust. There were huge hoof tracks in this almost dangerously civilized territory north of Deadwood, but there was no horse.

A month later Witchitaw was on the Great Northern. He had boarded her at Billings after withdrawing his three hundred. Almost simultaneously he became a frightened man. He had to go all the way to New York to reach Ashley's headquarters.

He wasn't frightened of Ash-

ley, just bitterly angry. But the wilds and the canyons and the loneliness of New York were frightening. This, to Witchitaw, was the great Deadlands.

And it became just that to Alexander Ashley, the millionaire manufacturer of canned dog food.

Witnesses said later he simply answered a ring at his apartment door and a voice said: "Draw," then later, "Turn around." The latter command was followed by two heavy shots; nobody saw the gunman. They commented on the unhurried evenness of his footsteps as he nonchalantly walked away.

There was something about the sound of them that was reminding of a slippered monk walking back to his vestry after doing a good turn.

The New York police never solved that killing, never were able to find a reason for it.

As for Witchitaw, he doesn't come out of the Deadlands much. He says he's getting old and that he's got an old pal in there whom he gets along with tolerable well. But folks discount that because as the years pass nobody yet has seen Witchitaw's pal.

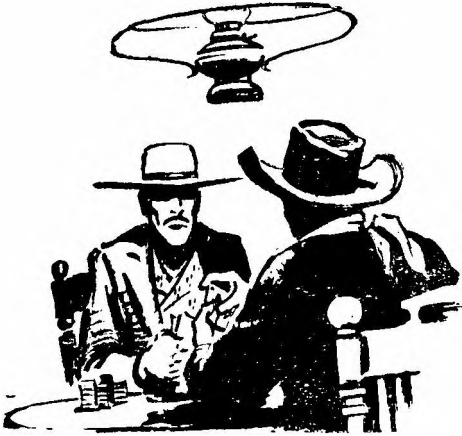

CONFIDENCE

by Art
Cleveland

Jarret had cleaned me, but now I had a chance to get mine back, if I could stay in the game with the hand I was holding ...

“I’M LETTIN’ you down easy this time, Mark,” Sid Jarret said, grinning that sly, wicked grin as he shoved more money into the pot. “I’m raisin’ you just a hundred!”

I felt kind of cold inside. I was already eight hundred loser in this draw poker game—eight hundred of the two thousand dollars I’d got for the cattle I’d shipped that morning, money I couldn’t afford to lose. There’d been a couple of others in the game when it started, but now it had narrowed down to just Sid Jarret and me.

I looked across at Jarret. He was a big, dark man with flabby jowls and cold little eyes. He owned the Frying Pan outfit—land he’d won at crooked poker, I’d heard—but he never pretended to do any work. His hands were soft and smooth. If I hadn’t got a couple of drinks under my belt I’d have had more sense than to sit down with him. But now it was done, and I *had* to try to get back that eight hundred.

I peeked again at my three jacks, a fair hand in any poker game. Jarret had drawn three cards.

"Call," I said, shoved in a hundred and flipped my cards.

Jarret spread his hand face up. He had three kings.

"Too bad, kid," he sneered, raking in the pot.

If he was cheating, I hadn't been able to catch him. Maybe a dozen men were gathered about the table, sweating the game, but the room was pretty quiet. They knew as well as I did that I couldn't afford to lose that money. They must have figured I was pretty dumb—a freckled, red-haired button of twenty settin' down with a poker wolf like Sid Jarret. But I was too stubborn to back down now.

I wanted to slam my fist into Jarret's grinning face. Instead, I said, "Yore deal—and yuh better deal 'em straight!"

His black eyes narrowed down. "What you mean by that, kid?"

"Just deal 'em." I said.

He dealt, and he won that pot, too. Pretty soon I was a thousand loser. That cold feeling was still in my stomach. If I went broke it meant more than just losing my money. It meant that likely Rose Tully wouldn't ever marry me. I'd

never seen a prettier girl than Rose. She'd promised to marry me next month. But she wouldn't marry anybody who'd been dumb enough to lose two thousand dollars in cow money.

JARRET kept on winning. Half a dozen times he just barely topped me. Seemed like he could read the backs of the cards.

Once Jim Sabin, who owned the saloon we were playing in, tapped me on the shoulder and said, "Don't you reckon you had enough, kid? You're outa yore class..."

"Let the kid alone," Sid Jarret said coldly. "It's his money, ain't it?"

"It sure is." I said. "My luck'll change!"

But it didn't, and pretty soon I was fifteen hundred loser. I knew then that I didn't have a chance, but I wouldn't quit.

"Mind if I take a hand, gentlemen?"

I looked up quick. A runty, pale-eyed little old gent stood there beside the table. He had a neatly trimmed spade beard that had gray in it. He wore a

black suit with a black string tie and a white shirt. I hadn't noticed him standing there watching the game, but I knew he must have been there behind me several minutes.

Nick Hawn owned the 77 outfit over along French Creek. I reckon he had more friends than any man on the Kettle-drum range. Once he'd been a gambler—a square gambler, I'd heard, and folks called him "Two-Card" Hawn—but he never played now except for low stakes with a few old cronies. He'd never more than spoken to me a few times.

Now Sid Jarret's agate eyes narrowed thoughtfully on Nick Hawn. He knew Hawn had once been a gambler, but he must have figured the oldtimer was out of practice and would be easy pickings.

"Your money's good as any, old man," Jarret said. "No limit, no table stakes—play all yuh got, can beg, borrow or steal!"

Nick Hawn nodded curtly and sat down. He took a roll of money from his pocket and placed it on the table before him.

THE GAME started up again. I didn't see how Nick Hawn being in the game would help me. Likely it would just mean more easy money for Sid Jarret.

I won the first pot, a small one, and Jarret won the next three. Jarret was grinning that cold, sly grin. Nick Hawn didn't seem to care much whether he won or lost. He played carefully, watching Jarret with his pale, wise old eyes. I could see he was feeling Jarret out, like a man feels out a gent he's fighting before leaping in for the kill.

Still, that wasn't helping me. I was down to my last two hundred. I could see a year's work—and a slender, yellow-haired girl named Rose—slipping away from me.

Nick Hawn won a couple of good pots off Jarret—and now Jarret had stopped grinning. He dealt more slowly, and there was a puzzled, uncertain light in his eyes.

Before starting this deal—the deal where I caught four kings cold—I saw Jarret look at me, then at Nick Hawn, before a kind of hood dropped over his black eyes. My heart

jumped up and hit me under the chin when I saw the four kings. Then it dropped back with a thud.

Even if I got a play on the kings, I didn't have enough money to get back but a tiny part of what I'd lost.

I LOOKED at Jarret and Nick Hawn. Jarret was frowning, peering at his cards. Hawn's gray face was expressionless. He seemed kind of bored.

It was my first bet. I didn't want to give my hand away by betting too much, so I shoved in fifty dollars. Nick Hawn shrugged, tossed in his hand. Jarret peered at his cards again, then very carefully placed them on the table face-down.

"Mark," he said, "I'm tired of playin' poker for today. I'll just raise the rest yuh got!"

I counted out my last hundred and fifty, cussin' the black luck that had given me four king cards and no money to back 'em up with.

"That's all the money I got, tinhorn—which is a lucky thing for you!" I said.

"Good hand, eh?" Jarret purred.

"Good enough to back up, if I had more money..."

"You got some land, ain't you?"

"Yeah, I got some land—"

"But no nerve, huh, kid?"

"Why, cuss dang yore mangy hide!" I yelled rearin' up. "Get on yore feet and I'll show yuh who's got nerve!"

"I didn't mean that kind of nerve," Jarret said, his eyes cold and merciless. "Remember, we ain't playin' table stakes. Yore little cow outfit ain't worth much, but it's worth something. Put it in the pot—or toss in your hand and give me the pot!"

I sat back down. I felt kind of pale inside. I'd worked hard to build up my little place on Hungry Creek. It was all I had. If I lost it, along with the money that was already gone, I'd be laughed out of the country.

EVERYBODY was looking at me. They knew Jarret had me where the hair was short. Nick Hawn was lighting a cigar, staring at me over the match.

Those five cards—the four

kings and a trey—seemed big as a barn in my hand. Not once in a million times would a man draw a hand that would beat four kings.

“Reckon that busts up the game,” Jarret said, reaching for the pot. “Tough luck, kid...”

“Just a minute, tinhorn!” I said. “Don’t get any grease on yore fingers off that pot. I’m callin’ yore bluff. My outfit ought to be worth four thousand, hadn’t it?”

Jarret settled back. I could see his eyes narrowing down warily as he looked at me. Then he grinned thinly.

“So you decided to ride that hand after all, huh?” he sneered. “Well, to me yore land’s worth just two thousand. I’ll put up the two thousand—you write out a bill of sale for yore land. We’ll put it all in this one pot. Take it or leave it!”

I took it. Sid Jarret counted out two thousand in cash. Jim Sabin brought pen and paper, and I wrote out a bill of sale in Jarret’s name for my outfit. Those four kings looked bigger and bigger all the time. I felt pretty good.

Nick Hawn hadn’t said a word. He just sat there, watching Jarret more than he did me through his cigar smoke.

NOW, AS I started to shove the paper into the pot, he spoke up sharply: “Just a minute, there, Mark Lyons! I’m makin’ you a little loan!”

The room got mighty quiet. Sid Jarret leaned forward.

“You’re *what?*” he demanded flatly.

“Why, makin’ the button a little loan,” Nick Hawn said calmly, and took a money belt from about his waist. “You might call it a kind of investment, in that hand of his. I believe he’s got yuh beat! Anything wrong in that?”

Jarret licked his lips, but said nothing. He watched with a kind of desperate fury in his eyes as Hawn started countin’ out big bills from the money belt.

“There’s fifteen thousand, kid,” Nick Hawn said. “Use yore own judgment—and pay me back when you get ready. I got confidence in you.”

“And I got confidence in this poker hand,” I said. “I’m seein’ yore two thousand, Jarret

—and raisin' yuh the fifteen!"

I never saw a man turn paler than Sid Jarret did.

"I ain't got that much money," he muttered.

"You got land," I said. "But no nerve. huh, Jarret?"

"I ain't takin' a chance on my land!" he said harshly.

He ripped his five cards in half. Then he got up and stalked out of Jim Sabin's saloon without looking back.

"He was bluffin' all the way," I said, grinning. "He knew I had 'im topped. There's yore fifteen thousand, Mister Hawn—with interest."

"Just the loan, Mark." Nick Hawn looked kind of sad as he put the money back into his money belt. "I got my interest in knowin' I helped a young gent who's about to marry a yellow-haired girl out of a bad jam."

"Jam? I already had my money won back with these four kings."

And I spread my poker hand face up.

NICK HAWN didn't even look at the cards.

"Even before I started playin'," he said, strapping the

money belt back about his thin waist. "I knew Sid Jarret had thumbnail marked every card in the deck. You couldn't feel the marks, Mark, because yore hands are tough from handling a rope and posthole digger and such like. But Jarret's soft hands could feel 'em, and so could mine. So I kind of messed up his marks, and added a few of my own. That made Jarret lose confidence in his own cards."

"You mean that skunk was playin' crooked cards on me?"

Nick Hawn nodded.

"When he dealt you that last cold hand, he was sure he had you beat. Then, when I loaned you the fifteen thousand to raise with, he wasn't sure. He got scared he'd read the marks wrong, and turned yellow."

"He knew I had him beat!" I grinned. "That's one time a tinhorn showed good sense, anyhow!"

"And one time you didn't," Nick Hawn said gently.

Slowly he turned over the four aces and a ten that Sid Jarret had torn in half and slammed face-down on the table. Then he turned and walked out into the sunshine.

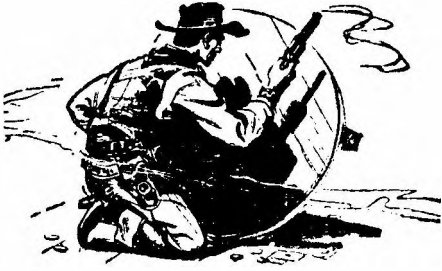

**talk
to
a
killer**

by J. J. MATHEWS

*Only one man could get
Pistol Pete to leave his
hideout without a bloody
fight — perhaps!*

THEY HAD Pistol Pete Clooney penned up down there on Whisky Creek. But that didn't mean they had him captured; it looked as if the dead might be stacked high before he was. For Pistol Pete was inside the Devil's Hook at the bend of the creek with plenty of grub, a box of extra shells, and a firm determination to rot in there before he came out to be hung. He had shouted that conviction out to Sheriff Mundy and his posse in several versions and with some choice expletives. Now the skinny, brick-faced sheriff strode the bank opposite the Devil's Hook and mopped his forehead worriedly.

He didn't know what to do. Pistol Pete was a dangerous gunslinger, tough as a stove-dried boot. His nerve wouldn't crack easily. He was wanted for the killing of a six-year-old girl by a stray bullet during a four-man gun battle in Creosote Forks and feeling was savage against him. If he failed to get Pete Clooney, the sheriff knew he might as well turn in his badge. That posse, spread along the creek bank, had fully intended to string him up on the

handiest cottonwood the minute they grabbed him. But none of them craved to go into the Hook to get him; it would have been little short of suicide.

"Well, what the blazes are you going to do, ya John Laws?" bawled a voice from down at the crossing. "Wait fer him to die of sheep tick?"

The sheriff mopped his head again and cut his eyes at Gerry, second in command of the posse, whom he had made a special deputy for the occasion. Gerry was one of the fastest trigger slammers down on Mogollon Flats, a cold-blooded big bull of a man. But Gerry just scrubbed his nose with the back of his hand and stared hard at the entrance to the Hook. Mundy looked up at the crossing. Something had to be done. There was a whole pack of folks there, waiting and watching, who'd come down the hill from nearby Elcinto to witness the payoff.

"We could draw lots," one of the other possemen said, stepping up. "The losers could rush him, say half of us. Mebbe one might wound him. Then the others could follow 'em in..."

Mundy was already shaking

his head. He knew the Devil's Hook, had been inside it himself. You couldn't rush that place. Because once you got inside the cavelike entrance, it narrowed to a thin corridor. Scooped out by the water in a great layer of rock ages ago when the creek was higher, it got its name from the way it hooked around in a sharp right angle about twenty feet back. And around the hook, it widened into a good-sized chamber. That was where Pistol Pete Clooney calmly waited now.

FIRING from around the wall of the bend, he could give them hell if they tried to get in. And always he could retreat into the chamber itself and plug them as they rounded the turn. It was a tough proposition. Mundy cursed softly as he gazed through the willows to where they had tethered Pistol Pete's horse and pack pony. That last meant the wanted man had toted in plenty of supplies with him, that he wasn't bluffing much when he'd yelled out he could sit it out forever and a day.

"Figure we could smoke him out, sheriff" Gerry finally

came up with a suggestion.

Again Mundy was forced to shake his head. He recalled eighteen or twenty years back when a posse had cornered Laredo Hallman in there. They had tried smoking him out but in vain. In the ceiling of the interior there were fissures that permitted the smoke to escape.

Fresh jeers came from the impatient mob up at the creek crossing. "You lily-livered pelicans, whyn't you go in. Do you need a special invitation?"

The sheriff's mouth hardened into a thin seam bisecting his red face. Then he pulled off his sombrero, removed his calfskin vest, and began peeling out of his shirt. There was one slim—d a n g e d slim—chance. And as the representative of the Law, it was up to him to take it. He would have possemen wade out into the shallows and pour a steady fire into the entrance as if preparing to rush it. Then he himself, after crossing to the other bank further down, would work his way up through the deep water with just his head and arms out and try to slip in unobserved in the excite-

ment. The creek flowed a few feet into the Hook. He might just catch Pistol Pete at the moment when his hogleg was empty. Or he might possibly get in a lucky shot and wound him before the cornered man spotted him. But the odds were heavily against either happening.

Gerry said, "Are you lo-coed?" after listening to the sheriff's plan.

L E A N M U N D Y shrugged as he dropped off his shirt. The breeze played around his bare fleshless ribs. Across two of them on the left side was an old dull-red bullet scar. Pistol Pete's brother Big Joe Clooney had given him that years ago when he had been a deputy. Mundy had put a slug in Big Joe's leg. But the man had gotten away from him. Later, Big Joe Clooney had been captured, served his time in the Big House, then disappeared after his release. And Pistol Pete was rated a slicker article with a hogleg than his brother. The sheriff sucked in his breath hard.

"If—if a n y t h i n g goes

wrong," he told Gerry, "tell my wife I..."

It was then that the traveling parson came around the bend downstream on his crow-bait. He was a tall gaunt man in rusty black, hollow-eyed, with the air of a big scarecrow. The bones protruded from his gaunt face. When he lifted his hat a moment it revealed thinning hair prematurely gray at the temples. He reined up, let his eyes swing over them, then pronounced:

"This looks like a scene of violence, brethren!" Mundy had a feeling he had heard that voice before, but it seemed unlikely. He never had given

much time to prayer meetings or revival rallies despite his wife's entreaties.

"It's Parson Joe Andrews, the miracle preacher!" cried one of the Elcinto citizens who had come down from the crossing. He told how the preacher had saved a man bitten by a rattler over at Wagonwheel last month. The sawbones had given up on the poor devil, pronounced him dead. But the parson had prayed through the night and somehow saved him. "He was wonderful, I tell you!"

"Mebbe he could git Pistol Pete outa that cave if he's so wonderful," said Gerry drily.

[Turn Page]

This was a dude to end all dudes — but they found that he was gun-poison. So an ambush-trap was set up for Lee Howell. Sarah would ask him out riding, in all innocence, and they'd be ready for him!

Don't miss this thrilling Range Novel

Gunslick Tenderfoot

featured in the August issue of

FAMOUS WESTERN

Now on sale at all stands

PARSON ANDREWS had dismounted and came walking through the willows, fixing them with a stern-eyed stare. "He who lives by the sword shall perish..." he started to quote, then broke off when he spotted Mundy's badge.

The Elcinto man stepped forward to pump the long-legged preacher's hand and explained the situation.

"It's Pistol Pete Clooney in there," the sheriff added.

The parson only nodded, then swung his gaze toward the town, Elcinto, up at the top of the long slope from the creek. But other townsfolk had come down the bank. Several more of them recognized the parson. They crowded around.

"Parson, you could get him to come out! You could!" several of them insisted. "They say you can talk the Devil to shame!"

Mundy sat down to remove his boots. He figured to be able to work upstream faster without them. "Better git back, folks."

"You'll die for sure if you try to go in," the parson said.

"You could do it, Parson Joe! You could!" the crowd in-

sisted. The possemen looked skeptical. An Elcinto man railed at them. "Don't sneer, you gents! The parson's a miracle-worker. And he ain't afeared of nothing, of nothing at all!"

Parson Andrews' stiffened. His burning eyes ran over the throng of people who so deeply believed in him. Then he removed his hat.

"Maybe I could do something," he said slowly, "I'll talk to him..."

BEFORE he did, the parson stepped back into the trees, turned his back on everybody, and stood several moments with bowed head. He drew something from an inside pocket and then seemed to be fussing with the buckle of his belt. Mundy wondered if the man was bluffing. Then the parson returned and clambered aboard one of the posse's ponies. The breeze plastered his flopping coat against his gaunt body. All his clothes seemed too loose for him. He faced the pony toward the cave across the stream and sang out:

"Pete Clooney! Pete Clooney in there?"

[Turn To Page 120]

Wonder Slim

OUR BEST MEN'S BELT

ONLY
4.98

**WORKS WONDERS FOR
YOUR BACK**

LOOK SLIM — FEEL TRIM

Wonder Slim is a new kind of men's support-er belt. Its ingenious contour design follows nature's own lines—permits remarkable freedom of movement, its patented sliding back panel makes it the easiest belt to put on—provides "quick as a flash" adjustment for constant perfect fit. No uncomfortable crutch. Scientific "no pressure" boning flattens the bulge gently but firmly. Sliding back provides support just where you need it for youthful posture—fights the feeling of fatigue. Made of super test herringbone twill. Waist sizes 26-44—Only \$4.98. Try it at our risk.

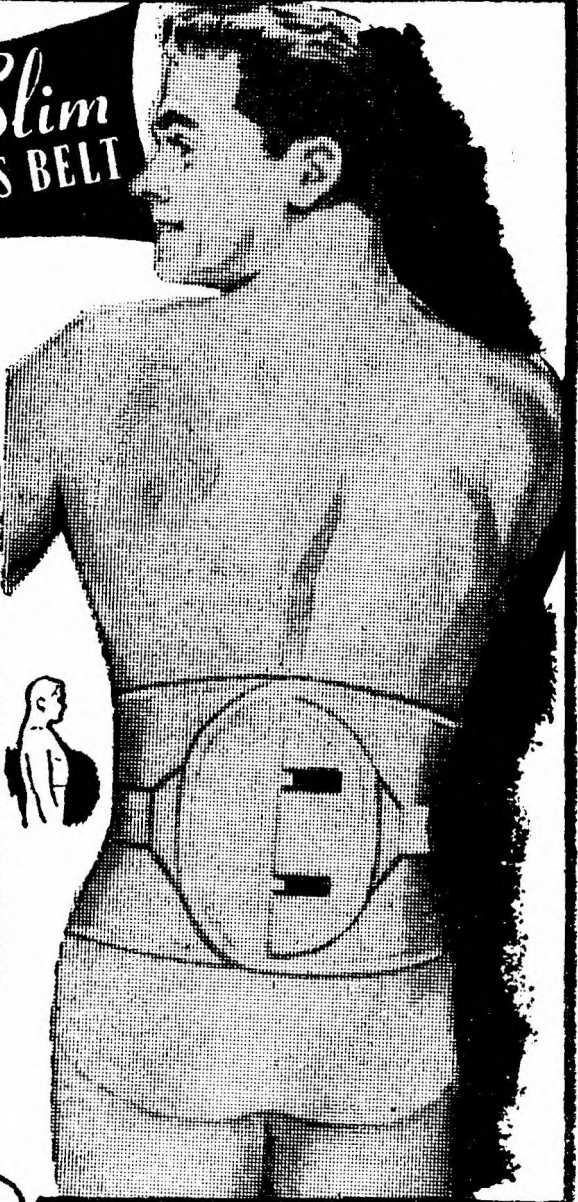

FEATURES

Takes inches off
waist
Action automatic
and keeps it to
Give vital back
support
Stabilizes sag-
ging stomach
muscles
Give your diaphragm
that outdoor
made look

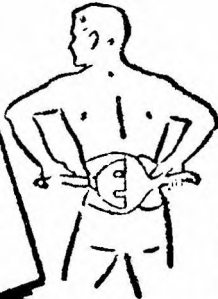

10 DAY TRIAL FREE

S. J. Wegman Co.
Lynbrook, N. Y.

Dept. WG-41

Rush my Wonder-Slim back supporter at once, if I am not 100% satisfied I may return it for prompt refund of the full purchase price.

Waist Size.....inches
 Send C.O.D. I'll pay postman \$4.98 plus a few cents postage.
 I enclose \$4.98 payment and save postage. Same Guarantee.
 Name.....
 Address.....

Immediate Comfort and Relief for You

with *Patented*

RUPTURE-EASER

T.M. Reg. U.S. Pat. Off. (A Piper Brace Truss)

For MEN, WOMEN and CHILDREN

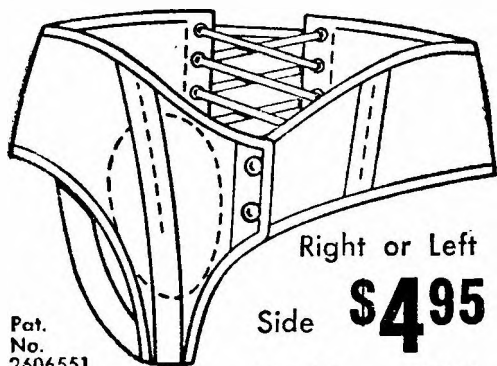

Pat.
No.
2606551

Right or Left

Side **\$4.95**

Double **\$5.95**

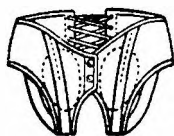

A strong, form fitting washable support designed to give you relief and comfort. Adjustable. Snaps up in front. Soft flat groin

pad—back-lacing and adjustable leg strap. **No steel or leather bands.** Unexcelled for comfort, **invisible under light clothing.** Washable. Also used as after operation support.

● **A MOST EFFECTIVE SUPPORT FOR REDUCIBLE INGUINAL HERNIA**

Hundreds of thousands of people have discovered wonderful new comfort with Rupture-Easer. Compare it yourself with conventional steel and leather trusses!

● **RUPTURE-EASER IS SANITARY**

Can be washed without harm to fabric—you never offend when you wear Rupture-Easer.

● **NO FITTING REQUIRED**

Just measure around the lowest part of the abdomen and specify right or left side or double.

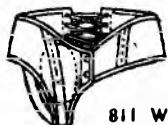

Order two for
change-off when
laundering.

PIPER BRACE CO.

Dept. DU-89

811 Wyandotte, Kansas City 5, Mo.

Canadian Orders—

Mail to: PIPER BRACE (Canada)

1242 MCGILL COLLEGE AVE.

MONTREAL, CANADA

“What the devil do you want now?” came back a muffled voice from inside the Hook. “Do you have to interrupt a man’s siesta?”

“I’m Parson Andrews!” the preacher man boomed. “I’m coming in to have a talk with you.”

“Stay out, parson!” Pistol Pete’s voice came back in sharp warning. “I’ve got four hoglegs and a carbine in here. Anybody who tries to come in gits a winda in his skull!”

“I’m coming in, Pete.”

“These Colts of mine are plumb aching for action!”

“I wear no Colts,” the preacher man called back. “I want none. And I’m coming in.” One of the posse offered him a .45 to stick inside of his shirt but the parson refused it. He started the pony across the creek.

The throng watched, breathing tightly. The current swirled up over the stirrups at mid-stream. It deepened nearer the ledge of rock in front of the Devil’s Hook. Pistol Pete was

[Turn To Page 122]

Catch More Fish... AUTOMATICALLY!

**SENSATIONAL BOB-O-MATIC CASTING FLOAT HOOKS
YOUR FISH AUTOMATICALLY THE INSTANT HE BITES**



Cast more effectively with Bob-O-Matic than with ordinary floating rigs because the weight is concentrated in one place close to the sinker and the baited hook

Here's a really clever new invention that now automatically enables you to catch those fish you've been losing. Human reaction is often too slow to set the hook at the right instant, so Bob-O-Matic does it for you automatically. The instant a fish bites—WHAM! the automatic trigger goes to work at lightning speed setting the hook firmly in the mouth of the fish in just 1/50 of a second. **YOUR FISH IS CAUGHT!** Takes only one second to re-set trigger. Fish over and over until you've caught more than you can carry. Don't delay! Order now and really enjoy fishing at its very best. Complete with instructions.

Bob-O-Matic floats upright to show you exactly where the bait is riding and automatically allows the bait to reach the depth you desire.

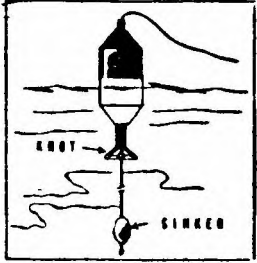

only
\$1.98

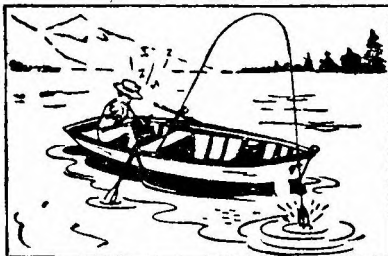

Bob-O-Matic assures you of coming home with the biggest catch and the most admiring glances. You can fish off a boat, a bridge, leave for a drink, or take a nap. Bob-O-Matic does the work for you. It hooks the fish and keeps him hooked.

- ### Sensational Features
- Slip line casts more effectively than ordinary float rig.
 - Automatically allows bait to reach desired depth
 - Permits reeling fish as close to rod tip as possible
 - May be used as fixed position bobber
 - Sets hook automatically in 1/50 of a second to assure a big catch.

Money Back Guarantee

Bob-O-Matic is guaranteed to catch fish automatically. If you're not 100% delighted, your money will be refunded.

Money Back Guarantee

Sportsman's Post Dept. BT-77
Lynbrook, N. Y.
Rush Bob-O-Matic automatic fisher to me at once on 10 day free trial offer at \$1.98

- Send C.O.D. I will pay postman on delivery plus a few cents postage
- I enclose payment. Sportsman's Post will pay postage

Name _____
Address _____



**Air
Cushion
RIPPLE
SOLE Shoes**



**Over 180 Styles
for Men, Women
and Children**

DON'T PAY FOR THESE GREAT SHOES!

**GET THEM WITHOUT COST
AS A REWARD - PLUS -
THE CHANCE TO "BE BOSS" OF YOUR
OWN \$10,000 A YEAR SHOE BUSINESS!**

Brand new plan! You can earn marvelous new shoes instead of paying for them - and develop an extra income for life! Sell friends Work, Dress, Casual Shoes and Boots in spare time. Revolutionary new leather soles guarantee twice the wear! Simple 2-finger demonstration of patented AIR CUSHION comfort makes shoe selling a snap! We back you with over a quarter million pairs in stock. Sizes 4 to 18, widths AAAA to EEEE. Also earn Advance Commissions to \$5.00 a pair, plus Big Bonus. No experience, no investment. Shoe samples supplied.

SEND FOR NEW OUTFIT!

Everything you need to succeed in an independent business of your own will be rushed to you - without obligation. You can't lose - write today!

**CHARLES CHESTER SHOE CO.
Dept. B-5944, Brockton 64, Mass.**

**EARN MORE MONEY -
BE A RADIO AND TV
ANNOUNCER!**

America's oldest broadcasting school offers you the opportunity to train at home for an exciting career in Radio and TV. Nationwide placement service for graduates.

Write today for FREE Catalog. . . Write Department DA-1.

**LEARN
AT HOME
ON TAPE!**

**MIDWESTERN BROADCASTING SCHOOL
228 S. WABASH AVE. CHICAGO 4, ILLINOIS**

watching; he yelled a warning to the parson to stop. Preacher Joe Andrews urged the horse ahead.

Then he was swinging from the saddle onto the ledge. "Here, I come, Pete. You can see I wear no gunbelt." And he ducked his head to disappear inside.

SHERIFF MUNDY swallowed audibly and cursed himself. He shouldn't have let that helpless fool try it. Pistol Pete was as dangerous as a coiled sidewinder, knowing the posse would make a cottonwood apple of him without bothering to take him back for trial.

Inside, the parson saw the dull-gleaming spike of the fugitive's gun barrel around the bend. He strode unhesitatingly

[Turn To Page 124]

MEN IMMEDIATE TRAINING AS HEAVY EQUIPMENT

AGES 17 TO 45

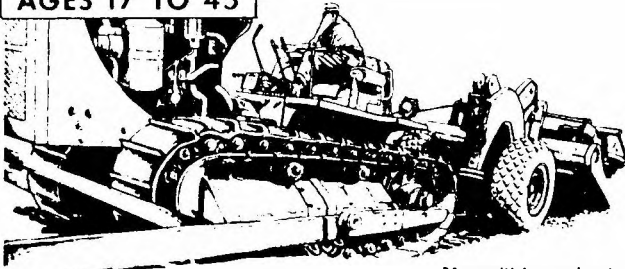

OPERATING ENGINEERS EXPERIENCE UNNECESSARY

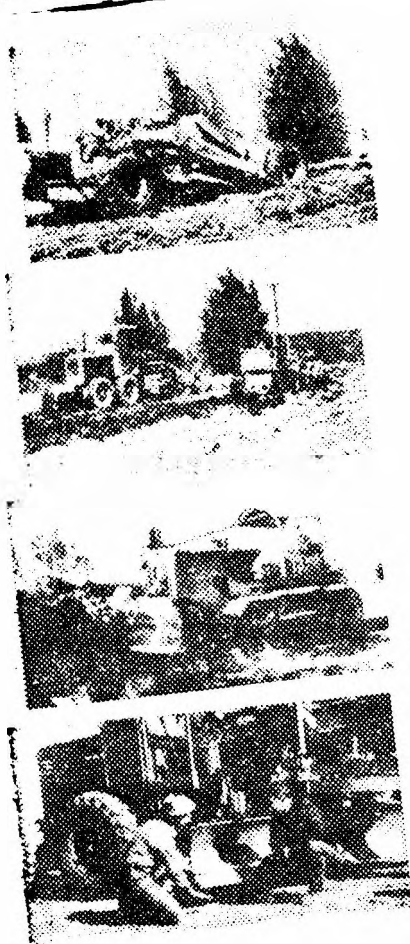

You will be trained thoroughly for modern heavy equipment operation. To meet requirements of new public and private, Federal, State and local highway, road, street, bridge, dam and other construction programs. Increase from former operator supply of 300,000 to 900,000 projected for next two years. Operators, with time off for winter, have been earning up to \$7,000-\$10,000. Advancement to foreman earns up to \$12,000 to \$15,000.

Master Heavy Equipment Operation:

- Tractors
- Scrapers
- Graders
- Rollers
- Ditchers
- Shovels
- Bulldozers
- Engineering Fundamentals
- Blueprint Reading
- Operating Controls
- Equipment Operation
- Field Maintenance
- Diesel Engine Operation
- Highway Construction, Etc.

Immediate nationwide placement service available without charge upon completion. Training starts at home.

If age 17 to 45, signify interest at once. Mail coupon below.

MAIL AT ONCE

HEAVY EQUIPMENT OPERATING ENGINEERS DIVISION

Northwest Schools, Inc. Dept. HF-92
11 East 47th St., New York 17, N.Y.

Rush information without obligation.

Name _____
 St. or Rte. _____
 P.O. _____ State _____
 Education _____
 Age _____ Phone _____

Tools and Hardware

WHOLESALE!

Start Your Own Business

Sell nationally advertised tools to your friends and neighbors. Also for your own industrial and institutional use. New giant wholesale catalog has room for only your name on it. You get all the orders and re-orders. A MILLION DOLLAR INVENTORY AT YOUR FINGERTIPS. NO STOCK TO CARRY. ORDER AS YOU NEED IT! . . . Stanley, Clemson, Disston, K. & E. Lufkin, Miller Falls, Wiss, S&K, Thor and many other name brand tools, appliances, electric tools, power tools and others, too numerous to mention. WHOLESALE DISCOUNTS UP TO 50% off . . . Send \$1 deposit and get the new giant wholesale catalog. Your \$1 is credited to your first purchase or refunded if not 100% satisfied. Write NOW!

HUGE PROFITS!
MORE MONEY!

Get up to
50%
off

U. S. SUPPLY CORP., DEPT. 211

403 Market St., Newark, New Jersey

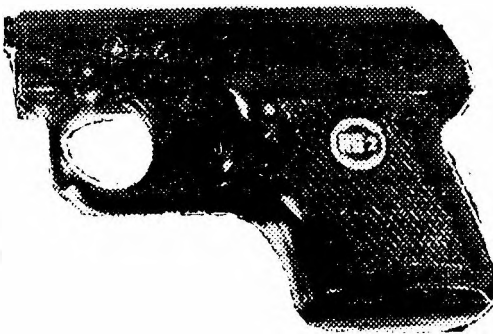

The skilled hand of the German gunsmith is responsible for this .22 calibre, 6-shot repeater automatic with self-ejecting clip. Just 4" long, fits easily into pocket or purse. Ideal for sporting events, stage use. (not available to Calif. residents). Comes for \$6.95 ppd. from **Best Values, Dept. G-160, 403 Market, Newark, New Jersey.**

through the shallow water and advanced. The gun vanished as Pistol Pete retreated back into the bigger chamber.

"When you round the turn, be praying!" he called. "And pray fast. 'Cause you won't have long, mister."

"My prayers are said," called back Parson Joe Andrews. "I've come to pray for *you*, Pete." He made the turn and stepped full into the glow of a chunk of candle the fugitive had burning on a can in the deeper chamber. Behind the candle, crouched against the back wall, waited Pistol Pete. a couple of big Colts levelled before him.

"Hello, Pete," said the parson. "I'm Parson Joe Andrews."

Pistol Pete's mouth shot open. His head thrust forward. Then his lean leather-hued face became an adamant mask once more, the dots of fiery eyes under the sun-bleached brows becoming again pinpoints of menace.

"So you thought you could talk me outa here, eh?" he

[Turn To Page 126]



EXPLODING ARMY HAND GRENADE

EXACT REPLICA only \$1.00

Here's real battle authenticity. This menacing hand grenade looks and works just like a real one. All you do is pull the pin, wait 4 seconds, throw the grenade, and watch the fun as it explodes automatically. It's completely harmless, but the explosion it makes can be heard for a block. Really scatters the gang when you throw this baby in their midst. It sure looks and sounds real. Can't break. Can be exploded over and over again. Heavy gauge steel firing mechanism. Only \$1 plus 25¢ shipping charges.

10 DAY FREE TRIAL

Don't delay! Order now! If not 100% delighted simply return for prompt refund of full purchase price.

----- MONEY BACK GUARANTEE -----

**HONOR HOUSE PRODUCTS CORP. Dept. HG-17
LYNBROOK, NEW YORK**

Rush me my exploding Hand Grenade at once. If I am not 100% delighted, I may return after 10 Day Free Trial for prompt refund of purchase price.

- I enclosed \$1 plus 25¢ shipping charges.
 Send C O D. I will pay postman on delivery & C. O. D. & shipping.

Name _____

Address _____

**PELLET FIRING "45" CAL.
AUTOMATIC** Magazine Loading Ammunition Clip — Has Automatic Slide Action — Over 15 Moving Parts

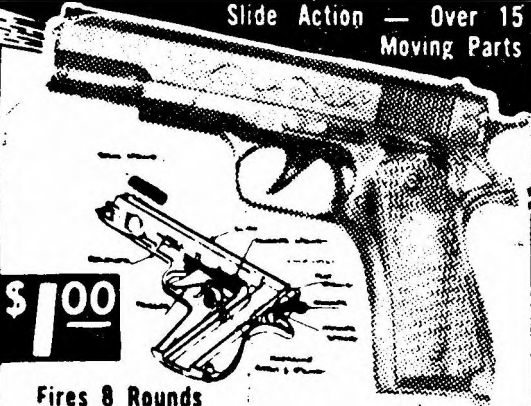

\$100

Fires 8 Rounds

An automatic full size model of a high powered "45" caliber automatic pistol that looks and feels just like the real thing and contains over 15 moving parts. Loads 8 complete rounds in the magazine clip which snaps into the hard butt just like an army "45". Then fires 8 bullet-like pellets as fast as you can pull the trigger. You've got to see the automatic slide action and feel the power to believe it! Great for shooting fun. This is the most authentic model gun we've ever seen.

Learn the Working Mechanism of a "45"

This accurate model of a high-powered, "45" comes to you disassembled with all the working parts of a "45". It assembles in a jiffy and full instructions are included so that in no time at all, you'll learn working parts of an automatic. Comes with instructions, full supply of pellets and man-sized silhouette target.

10 Day Free Trial

Try it for 10 days free. If you are not 100% delighted simply return after 10 days for prompt refund of full purchase price. Don't delay! Order now! Simply send \$1 plus 25c shipping charge to:

**HONOR HOUSE PRODUCTS Dept. AP-41
Lynbrook, N. Y.**

snapped in his dry husky voice.

PUSHING back his coat, the parson advanced to within a couple of yards. He nodded. Their eyes scoured each other slowly.

"You got to come out, Pete. A heap of men will get killed if you fight. And sooner or later, they'll get you."

Pistol Pete's mouth twisted. "Don't give me the soft talk, Joe. Mebbe they'll git tired of dying. They can go to..." He was going to say "hell" but didn't.

"Killing is bad stuff, Pete. I know. Either you pay for it on this earth or in the hereafter, Pete."

"Don't try to scare me, Joe," Pistol Pete sneered. His guns had lowered but he still radiated men-

[Turn Page]

Find **HIDDEN TREASURES**

GOLD, SILVER, PRECIOUS METALS with the Famous Model 27 Metal Detector. Lightweight, ultra-sensitive, low cost. None finer. Also GEIGER COUNTERS for uranium and the VIOLITE for tungsten. INFORMATION FREE

THE *Detectron* CORP. Dept. G-1
5528 Vineland Ave., No. Hollywood, Calif.

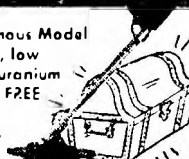

ace. "I'll play my cards my own way."

The parson sighed and bumped his head against a protuberance on the roof of the cave as he shifted. "In the name of the Lord, Pete, I'm asking you to surrender! You can't escape, Pete."

Pistol Pete sagged a little, moving out from the back wall. He put one of his guns on the can beside the candle and picked up an open bottle of redevye. After a slug, he shook his head again. A snarl formed on his mouth.

"No! I won't! I never killed that girl in Creosote Forks, but they hunted me down like a coyote. Tried to kill me without a trial! They made the rules of the game. So now let the dang coyotes pay my price if they want me!"

"Blood-letting settles nothing, Pete!" Parson Joe pleaded. "Vengeance belongs to the Almighty. Come out and..."

"They'd string me up the moment they got their dew-claws on me!"

"I'll get 'em to swear they

[Turn Page]

HARD OF HEARING?

No other hearing aids
are so unnoticeable yet
so powerful as Radioear!

NEW! Extra-powerful EYEGGLASS HEARING AID . . .

does not advertise your hearing loss. No button, or dangling cord. Only a thin transparent tube leads to the ear. *So slim* your friends will think you're wearing ordinary eyeglasses. Inside the trim temple is a tiny STEREO hearing aid—so powerful, it gives you *hearing volume* you never thought possible again. For stereophonic hearing, you can have a STEREO in each temple.

Choose your eyeglass frame in any style—Stereo temples can be decorated as desired.

NEW! Extra-powerful BEHIND-THE-EAR HEARING AID

—the Radioear STEREOette—fits comfortably. is beautifully concealed. You enjoy startling clarity of hearing, without clothing noise. The amazingly compact STEREOette weighs less than $\frac{1}{2}$ oz. Gives clear, understandable hearing for 8 out of 10 who need help! For a new dimension in hearing, two-ear, stereophonic hearing is available.

Specially contoured for each ear, the STEREOette lets you hear at ear-level . . . as nature intended.

*For complete information, write today
for Booklet No. 606.*

radioear CORPORATION

The World's Finest Hearing Aids • CANONSBURG, PA.

\$10,000 a year selling steel shelving-parts bins-cabinets-shop equipment. Sold everywhere! Terrific commissions. Free 32 page catalog-jobber discounts. **BFC Corporation, 2910E Hedley, Phila. 37, Pa.**

Give a "YOU-R-MINE" Ring



Give a "YOU-R-MINE" Ring as an endearing token of your sentiment. A beautiful Sterling Silver Rodium plated Ring with black inlay. State boy's and girl's initials for free engraving.

only \$2.00 for hers | PLEASE REMIT
or \$3.00 for his | WITH ORDER

Meyer E. Wolf Co. 580 5th Ave. N. Y. 36, N. Y.

RUPTURED

BE FREE FROM TRUSS SLAVERY

Surely you want to **THROW AWAY TRUSSES FOREVER**, be rid of Rupture Worries. Then Why Do you put up with wearing a griping, chafing and unsanitary truss the balance of your life? If you do, it will **NOT** be through necessity but through choice on your part.

Now there is a new modern Non-Surgical treatment that is designed to permanently correct rupture. These Non-Surgical treatments are so certain, that a Lifetime Certificate of Assurance is given. Write today for our New **FREE** Book that gives facts that may save you painful, expensive surgery. Tells how non-surgically you may again work, live, play, love and enjoy life in the manner you desire. There is no obligation. Excelsior Medical Clinic, Dept. H2324, Excelsior Springs, Mo.

PEOPLE 50 to 80

TEAR OUT THIS AD

...and mail it today to find out how you can still apply for a \$1,000 life insurance policy to help take care of final expenses without burdening your family.

You handle the entire transaction by mail with **OLD AMERICAN** of **KANSAS CITY**. No obligation. No one will call on you!

Write today, simply giving your name, address and year of birth. Mail to Old American Insurance Co., 1 West 9th, Dept. L479N, Kansas City, Mo.

won't—to promise to take you back for trial!"

Pistol Pete shook his head. "Naw! Halfway down the trail, they'd forgit their word... Now, git out, Joe. Git out! I can hold out for weeks—till they git a bellyful. Only thing I forgot to bring in with me was some chewing tobacco. But..."

"Here." The parson poked in a coat pocket and brought out a slab of cut plug. "Take half, Pete."

The fugitive grabbed it. Then he put down his second Colts and produced a knife to split the plug. The parson's right hand moved to the waistband of his trousers. Pistol Pete's beads of eyes jumped.

"Don't you think it'd be better to come
[Turn To Page 130]

at last... a complete, modern guide to lasting mutual sexual happiness for all couples.

Illustrated SEX FACTS

By DR. A. WILLY, DR. L. VANDER, DR. O. FISHER
AND OTHER AUTHORITIES

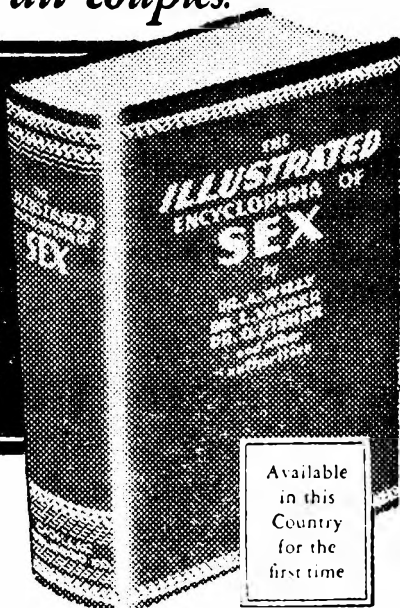

THIS GIANT SIZE BOOK CONTAINS HUNDREDS OF AUTHENTIC, ENLIGHTENING ILLUSTRATIONS — many in life-like color.

New available to the public in this country, for the first time, is this big guide to modern married sex practice. Written and illustrated by the most noted physicians and medical artists on sexual enlightenment. See and read how you can acquire enduring, harmonious married love by means of hundreds of exclusive, authentic pictures (many in true-to-life color), plus detailed step-by-step instructions written frankly and simply. This complete, large book includes important NEW information and illustrations never released here before. This book is a frank, straightforward presentation of facts to satisfy mature interest in the sex functions of the human male and female. Gives the most helpful authoritative guidance on sex problems of every kind—both abnormal as well as normal. Clearly understand and see the physiology and functions of the sex organs of both male and female. Many troubled men and women have found a new, happy married sex life and new confidence in themselves by reading "The Illustrated Encyclopedia of Sex." Sells for \$5.00—but it is yours for the amazing low friend-winning price of only \$2.98. This offer good for a limited time only. Mail coupon NOW!

**PARTIAL LIST OF 61 BIG CHAPTERS
EACH A "BOOK" IN ITSELF**

- Techniques that bring complete gratification to the sex act for male and female
- What causes climax in women
- Blunders made by men in sex act. How to avoid them
- Technique of first sex act on bridal night
- Why woman fails to attain climax
- Husband and wife attaining mutual climax
- How male organs function in intercourse
- How female sex organs function in intercourse
- How sexual urge in woman differs from man
- Woman's perfect complete sexual satisfaction
- How to derive perfection in sexual act
- Reactions of man and woman during sexual relations compared
- The truth about sex victimizing that impairs sexual powers
- Natural birth control
- New discoveries in birth control
- Woman's fertile days
- Causes of sex drive in women
- Female frigidity: its causes and cures
- Causes and cures for sexual impotence in men
- Abnormal sex organs and what can be done
- How to correct male's premature climax
- Delaying sex life's finish
- Male change of life and its effects
- Causes and treatment of male and female sterility
- Feminine self-satisfaction
- Causes of sexual urge in men
- How sex activity affects weight of male and female
- How to use preparatory love towards greater satisfaction in sex act

Just a few of hundreds of frank, enlightening illustrated instructional
PARTIAL LIST OF ILLUSTRATIONS WITH AUTHENTIC COLOR PICTURES!

- Male Sex Organs
- Showing functions of male sex organ
- Illustrating effects on breasts after pregnancy
- Showing areas of woman's organs producing highest sensations
- Watch step-by-step growth of child in pregnancy
- Complete Color Picture Story of Woman's Sex Organs
- Pictorial Story of Woman's "SAFE" days
- Picture Story of Cause of Sterility in women
- Cross Section of the Hymen in Various Stages
- Cross Section Showing Cause of Woman's sexual ills
- Picture Story of normal Sexuality in male
- Picture Story of Woman's Sensation Curve
- Picture Story of most important cause of impotence
- Two Inserts of Female Bodies showing how pregnancy takes place

... plus many more pictured instructions

SEND NO MONEY! FREE 10 DAY TRIAL COUPON

CADILLAC PUBLISHING CO., Dept. F-287
220 Fifth Avenue, New York 1, New York

Send me "The Illustrated Encyclopedia of Sex" in plain wrapper marked "personal." I will pay postman \$2.98, plus postage on delivery (sells for \$5.00). If not completely delighted within 10 days, I can return book and my money will be refunded. I am over 21.

NAME _____
ADDRESS _____
CITY _____ ZONE _____ STATE _____

Check here if you wish to save postage, by enclosing with coupon only \$2.98. Same Money-Back Guarantee!
(CANADIAN ORDERS \$3.50. NO COD's.)

out alive, Pete," the gaunt parson said softly. "Alive... I'll git their promise, I swear."

Pistol Pete's lips curled away from his teeth. His eyes switched to his discarded guns. Then he shrugged. "All right..."

AT A STEADY hand lope, the posse moved through the night back to Mogollon Flats. They were keeping their word they had given to Parson Andrews. After all, when you made a promise to a man with so much dang nerve... Up front, beside the sheriff, Pistol Pete hummed cheerfully, confident he would be found innocent at the trial. When they drew up in a hollow for a breather, Mundy rolled a quirly for the handcuffed Pistol Pete and fired it up. Mundy could still hardly believe it had come off.

"Still can't figure how you come to surrender to that parson, Pete," he said. "I figured you'd blast him when he got inside. Or mebbe use him as a hostage."

Pete Clooney exhaled smoke. "Couldn't hardly do that with my own brother, sheriff."

"Your—your brother? Big Joe? But he..."

Pistol Pete nodded. "That was him, sheriff. Didn't know it myself till he came in. He's shed a heap of weight, so it's no wonder you didn't recognize him. 'Andrews' is the name of our mother's family, you see."

Mundy digested that. "I'll be danged! Well—Big Joe himself, eh. Still, how even he got you to surrender, him being unarmed and—"

Pistol Pete chuckled. "Unarmed? Like hell he was. He waited till I put my guns down, then let me see that .41 Gambler's Special he toted in a special pocket in the waistband of his pants. It was come out or git drilled in there—for me."

They rode on a couple of miles before the sheriff spoke again. "Pete, mebbe—well, mebbe it'd be better if we let folks think he was unarmed and talked you inta coming out. Folks believe in that parson."

Pistol Pete grinned under the moon, then nodded. "Sure. He's one convincing fella..."



PERSONALIZED HOME BAR

ONLY
\$5.98
*Personally Initialed
 It's Portable
 For Parties,
 Gatherings
 Basement*

This handsome portable Home Bar, personalized with your initials in a striking 3-dimensional contrast, makes it easy to serve guests in style. Made for both indoor and outdoor use. Its handsome contrast of wood grain and gold finish makes for a sparkling setting in the home. Adds class to any party or gathering, and points up the cleverness of its proud owner. And, for relaxing at home, in the parlor, den or basement it's certainly a convenient, handsome addition. Only \$5.98. Comparable in satisfaction and utility to bars selling for \$30. A perfect gift for any occasion.

10 DAY FREE TRIAL

Order today! If not delighted return for refund. Because of its large size we are forced to ask for 63¢ shipping charges.

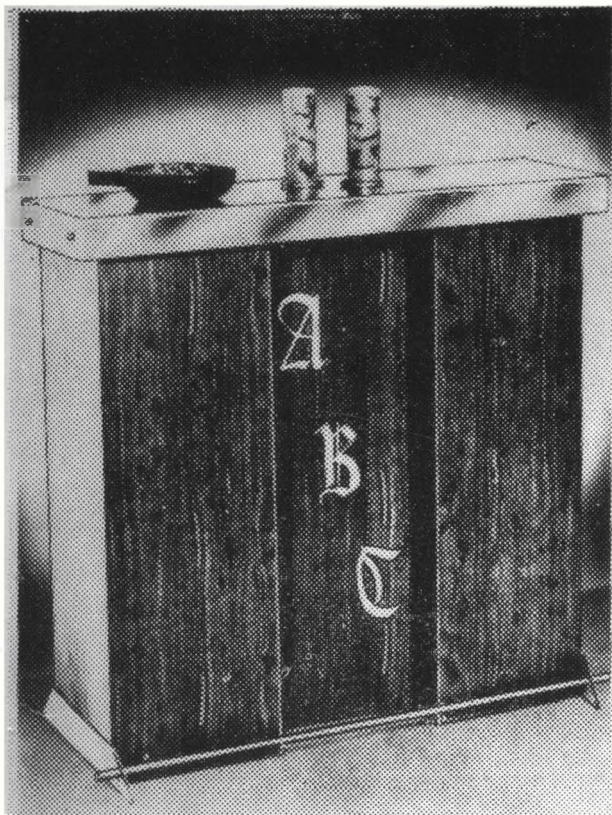

FEATURES

- Personalized With Your Initials
- It's Portable—Sets Up Indoors Or Out
- Built-in Shelf Holds Full Party Supplies
- Stain Resistant Bar Top

It's Big—39" wide, 38" high, 13" deep

Sturdily built of aluminum laminated and wood grain finished Multi Flute Fibreboard, this handsome personalized Home Bar is resistant to alcohol and soda stains. Handy built-in shelf holds full supply of bottles, glasses and napkins. Full size bar top holds drinks, pretzels, chips, etc. Sets up in a jiffy and folds compact for easy storage. A beauty for your home, and a novel gift. State initials desired with each order.

MONEY BACK GUARANTEE

S. J. Wegman Co., Dept. RB-41
 LYNBROOK, NEW YORK

Rush my new personalized portable Home Bar at once. If I am not delighted I may return it after ten days Free Trial for prompt refund of full purchase price.

- Send C.O.D. I will pay postman on delivery plus C.O.D. shipping charges.
 I enclose \$5.98 plus shipping charges.

NAME

ADDRESS

MY INITIALS ARE

NEW DISCOVERY IN HYPNOTISM

shows how to hypnotize
in 30 seconds!

Yes, an amazing new method has been developed to bring on quick, easy induction of the hypnotic trance. Now, for the first time, you too can benefit from this recent discovery in hypnotic induction.

QUICK RESULTS

Want to hypnotize your friends? Your club members? **HOW TO HYPNOTIZE** is a remarkable primer that shows you just how to master the latest improved induction methods. The author, a widely experienced hypnotist and consultant, gives you the exact positions to take, the precise phraseology, all the steps necessary to hypnotize even the most difficult subjects.



EXCLUSIVELY

in How to HYPNOTIZE

ENTIRELY NEW METHOD

Until recently the process of hypnotic induction was largely based on trial and error methods which succeeded mainly with subjects who were highly susceptible to hypnosis in the first place. The truth is that these highly susceptible subjects make up a very small percentage of the population. That is why amateurs and beginning hypnotists have so often been disappointed in their attempts at trance induction. Now, however, recent scientific research has developed **ENTIRELY NEW METHODS** that are not only sure fire in their results but quick and easy to achieve! For the first time, these new methods are presented in **HOW TO HYPNOTIZE** in language that you can easily and successfully follow on the very first reading!

Photographically Illustrated
40 photographic illustrations show how you can achieve trance induction in as little as 30 seconds!

FREE 10-DAY OFFER

FREE 10-day examination of this book is offered to you if you mail us coupon today. If not delighted with results return it within 10 days for a full refund of the purchase price.

FREE 10-DAY OFFER
Mail Coupon Today



SHOWS YOU STEP BY STEP

This book — which has been acclaimed by doctors and psychologists — is guaranteed to give you all the know-how necessary to induce the trance state in others. It not only explains the latest discoveries in hypnotic induction, but it shows step by step, move by move, exactly how to bring on the trance; how to transform the trance into deeper and still deeper states; and how to terminate the trance quickly and effectively without any dangers whatsoever. You are even given alternative methods, so that you can actually choose the one that suits you best.

USED BY DOCTORS

The book that is being used by doctors and psychologists to learn hypnotic induction is now available to you

\$1.98

FOR ONLY

GUARANTEE

This guarantees you that **HOW TO HYPNOTIZE** will show you how to induce the trance, or your purchase price will be refunded upon return of the book. Signed, **BOND BOOK**

Bond Book Co., Dept. **HK-239**
43 W. 61st Street, New York 23, N.Y.

Send **How to Hypnotize** for 10 day Free trial. My purchase price will be promptly refunded if I'm not satisfied.

- Send C.O.D. I'll pay postman \$1.98 plus postage.
 I enclose \$1.98. Bond Book pays postage.

NAME _____

ADDRESS _____

CITY _____

STATE _____